

# **SD2 Series 2900**

**Installation, Operation & Maintenance Manual**

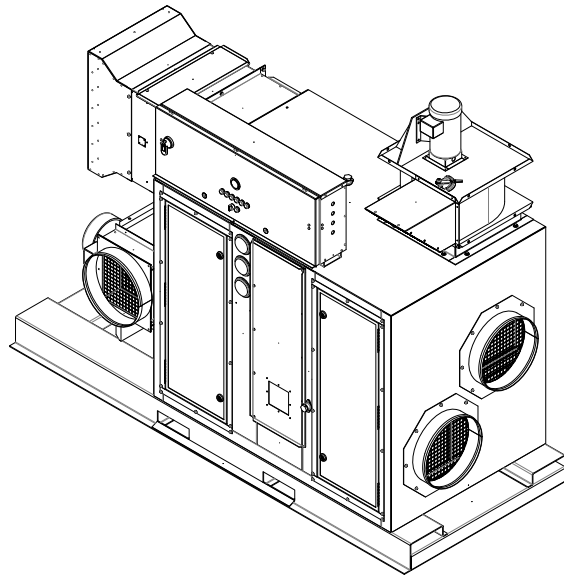

**Models:**

**SD2-5000-96-E**

**SD2-5000-96-G**

**Desiccant  
Dehumidification  
Systems**

**STULZ**  
Air Technology Systems, Inc.

## Notice

This document contains information protected by copyright. All rights are reserved. The owner of the equipment for which this manual is written may photocopy the contents of this manual for internal use only. No part of this document may be photocopied, reproduced, or translated into another language for use by anyone other than the owner of the equipment for which this manual is written without the prior written consent of Stulz Air Technology Systems, Inc. (SATS).

This document contains confidential and proprietary information of Stulz Air Technology Systems, Inc. Distributing or photocopying this document for external distribution is in direct violation of U.S. copyright laws and is strictly prohibited without the express written consent of SATS.

Unpublished - rights reserved under the copyright laws of the United States and of other countries.  
Other brands and trade names are trademarks of their respective owners.

Copyright 2011 by Stulz Air Technology Systems, Inc.  
Printed in the United States of America.  
All rights reserved.

**Stulz Air Technology Systems, Inc.**  
**1572 Tilco Drive**  
**Frederick, MD 21704**  
**USA**



## Table of Contents

|                                                                              |    |                                                     |    |
|------------------------------------------------------------------------------|----|-----------------------------------------------------|----|
| <b>1.0 GENERAL INFORMATION</b> .....                                         | 1  | <b>5.0 OPTIONAL FEATURES</b> .....                  | 18 |
| 1.1 Forward.....                                                             | 1  | 5.1.1 Burner Gauge.....                             | 18 |
| 1.2 Safety Summary .....                                                     | 1  | 5.1.2 Filter Gauges.....                            | 18 |
| 1.3 Warnings & Cautions.....                                                 | 1  | 5.1.3 Voltage Sensor/ Phase Monitor.....            | 18 |
| 1.4 Product Warranty.....                                                    | 3  | 5.1.4 Emergency Stop.....                           | 18 |
| 1.4.1 Dehumidifier.....                                                      | 3  | 5.1.5 Electrical Disconnect.....                    | 18 |
| 1.4.2 Desiccant Rotor .....                                                  | 3  | 5.1.6 Spare Rotor Belt.....                         | 18 |
| 1.5 General Theory of Operation .....                                        | 4  | 5.1.7 Electrical Enclosure Heater .....             | 19 |
| 1.6 Construction.....                                                        | 5  | 5.1.8 Customer Interface Terminals.....             | 19 |
| 1.6.1 Cabinet .....                                                          | 5  | 5.1.9 Auxiliary Control Terminals .....             | 19 |
| 1.6.2 Inlets and Outlets.....                                                | 5  | <b>6.0 PREVENTIVE MAINTENANCE</b> .....             | 20 |
| 1.6.3 Dehumidifier Identification Number.....                                | 5  | 6.1 Monthly.....                                    | 20 |
| 1.6.4 SD2 Series 2900 Dehumidifier<br>Identification Number (DIN) Sheet..... | 6  | 6.2 Yearly .....                                    | 20 |
| <b>2.0 INSTALLATION</b> .....                                                | 7  | 6.3 Desiccant Rotor Drive Motor<br>Maintenance..... | 20 |
| 2.1 Receipt of the Unit .....                                                | 7  | 6.4 Blower Motor Maintenance.....                   | 20 |
| 2.2 Rigging .....                                                            | 7  | 6.4.1 General Inspection .....                      | 20 |
| 2.3 System Location and Clearance.....                                       | 7  | 6.4.2 Lubrication & Bearings .....                  | 21 |
| 2.4 Connecting Ductwork.....                                                 | 8  | 6.4.3 Lubrication Procedure .....                   | 22 |
| 2.5 Utility Connections.....                                                 | 8  | <b>7.0 TROUBLESHOOTING</b> .....                    | 23 |
| 2.5.1 Power Hookup .....                                                     | 8  | 7.1 Troubleshooting Fault Lamps.....                | 25 |
| 2.5.2 Gas Connections .....                                                  | 8  | <b>8.0 REPAIR PROCEDURES</b> .....                  | 27 |
| 2.6 Installing a Humidistat or RH<br>Transmitter.....                        | 9  | 8.1 General Rotor Handling Guidelines....           | 27 |
| <b>3.0 OPERATION</b> .....                                                   | 10 | 8.2 Drive Belt Replacement.....                     | 27 |
| 3.1 Installation Checks.....                                                 | 10 | 8.2.1 Removing the Old Belt .....                   | 28 |
| 3.2 Start-Up .....                                                           | 10 | 8.2.2 Installing the New Belt.....                  | 29 |
| 3.3 Initial Start-Up for Gas Fired Units.....                                | 11 | 8.3 Replacing Seals .....                           | 30 |
| 3.3.1 Gas Train Ignition Sequence .....                                      | 11 | 8.3.1 Removing Old Face Seals.....                  | 30 |
| 3.3.2 Gas Burner System Start-Up.....                                        | 11 | 8.3.2 Installing New Face Seals .....               | 30 |
| 3.3.3 Gas Burner Set-Up/ Adjustment .....                                    | 11 | 8.3.3 Replacing Peripheral Seals .....              | 30 |
| 3.4 System Controller .....                                                  | 13 | 8.4 Rotor Cleaning Instructions .....               | 31 |
| 3.5 Capacity Control .....                                                   | 13 | 8.4.1 Preparation.....                              | 31 |
| 3.5.1 D-Stat .....                                                           | 13 | 8.4.2 Unit Shut Down .....                          | 31 |
| 3.6 Reactivation Types .....                                                 | 14 | 8.4.3 Cleaning .....                                | 32 |
| 3.6.1 Electric Reactivation .....                                            | 14 | 8.5 Rotor Repair .....                              | 33 |
| 3.6.2 Direct Gas-fired Reactivation.....                                     | 14 | <b>9.0 SATS PRODUCT SUPPORT</b> .....               | 34 |
| 3.7 Control Panel-.....                                                      | 15 | 9.1 Technical Support .....                         | 34 |
| 3.7.1 Mode Selector Switch.....                                              | 15 | 9.2 Obtaining Warranty Parts.....                   | 34 |
| 3.7.2 Sample Nameplate .....                                                 | 15 | 9.3 Obtaining Spare/Replacement Parts..             | 34 |
| 3.7.3 Hour Meter.....                                                        | 15 |                                                     |    |
| 3.7.4 Control Panel Lights .....                                             | 16 |                                                     |    |
| 3.7.5 Optional Status Indication Lights .....                                | 16 |                                                     |    |
| <b>4.0 UNIT FEATURES</b> .....                                               | 17 |                                                     |    |
| 4.1.1 Control Sensor Terminals.....                                          | 17 |                                                     |    |
| 4.1.2 Overheat Reset Push Button .....                                       | 17 |                                                     |    |
| 4.1.4 Monitoring Unit Performance .....                                      | 17 |                                                     |    |
| 4.1.5 Reactivation Air Proving Switch.....                                   | 17 |                                                     |    |
| 4.1.6 Test Ports .....                                                       | 17 |                                                     |    |

**List of Figures**

Figure 1 - General Theory of Operation ..... 4  
 Figure 2 - General Layout ..... 5  
 Figure 3 - Locating Wall-Mounted Control  
 Sensor ..... 9  
 Figure 4 - Burner Control Relay Module ..... 12  
 Figure 5 - Burner Assembly ..... 12  
 Figure 6 - Gas Train Assembly ..... 13  
 Figure 7 - Control Panel ..... 15  
 Figure 8 - Sample SATS Nameplate ..... 15  
 Figure 9 - Differential Pressure Gauges ..... 17  
 Figure 10 - Rotor Assembly Parts ..... 28  
 Figure 11 - Face/Peripheral Seal Union ..... 29  
 Figure 12 - Raising the Rotor ..... 29  
 Figure 13 - Peripheral Seal, Edge View ..... 31  
 Figure 14 - Rotor Washing ..... 32  
 Figure 15 - Rotor Scratch Repair ..... 33

**List of Tables**

Table 1 - Lubrication Intervals ..... 21  
 Table 2 - Service Conditions ..... 21  
 Table 3 - Lubrication Interval Multiplier ..... 22  
 Table 4 - Bearing Sizes and Types ..... 22

**Appendices**

**Appendix A, Forms**

Installation Checklist ..... A1  
 Maintenance & Service Checklist ..... A2

**Appendix B**

Unit Performance Curves ..... B

**Appendix C**

Glossary ..... C

## 1.0 GENERAL INFORMATION

### 1.1 Forward

Congratulations, the *DESICAiR SD2 Series 2900* dehumidification system covered by this manual is designed and manufactured by Stulz Air Technology Systems, Inc. Recognized as a world leader, Stulz Air Technology Systems, Inc. (SATS) provides dehumidification systems manufactured with the highest quality craftsmanship using the finest materials available in the industry. The unit will provide years of trouble free service if it is installed, operated and maintained in accordance with this manual. Damage to the unit from improper installation, operation or maintenance is not covered by the warranty.

STUDY the instructions contained in this manual. They must be followed to avoid difficulties. Spare parts are available from Stulz Air Technology Systems to ensure continuous operation. Using substitute parts or bypassing electrical or refrigeration components in order to continue operation is not recommended and will VOID THE WARRANTY.

### 1.2 Safety Summary

Read and understand all instructions, recommendations, and guidelines in this manual regarding the installation, maintenance, and operation of this unit prior to installation and start-up. All maintenance and repairs should be conducted by personnel thoroughly trained in the operation and maintenance of this or like equipment.

The input power supply to the equipment must be shut off before beginning work on the equipment. Take extreme care to ensure that every capacitor likely to hold electrical charge has been grounded. Always remove all rings, watches, and other jewelry when working on electrical equipment. Some of the equipment used may present the hazard of Electrostatic Discharge (ESD). When working inside the equipment, always ground all parts before touching. When possible, use a wrist grounding strap while working on or near ESD sensitive components.

Never operate the unit with any cover, screen, guard, panel, etc., removed unless the instructions specifically state to do so, and then, do so with extreme caution to avoid personal

injury. Never attempt to lift any component in excess of 35 pounds without additional help.

Placards and/or stickers have been placed in various locations on or in the unit. These placards/stickers are intended to call attention to personal safety and equipment damage hazards.

Certain maintenance and cleaning procedures may either recommend or specify the use of solvents, chemicals, or cleansers. Always refer to the Manufacturers Material Safety Data Sheet (MSDS) prior to the handling of any of these solvents, chemicals, or cleansers.

### 1.3 Warnings & Cautions

The following is a condensed list of WARNINGS and CAUTIONS that are noted throughout this manual. All personnel who operate, maintain or service this dehumidifier should read and understand these WARNINGS and CAUTIONS. All WARNINGS indicate a potential threat to personnel and all CAUTIONS indicate a potential threat of equipment damage.



**WARNING** Voltages used with this unit can be deadly. Be careful not to contact high AC input voltage connections when installing or operating this equipment. Use the services of a qualified electrician and/or technician to make the electrical power connections and perform maintenance.





**WARNING DISCONNECT THE MAIN POWER SOURCE TO THE UNIT PRIOR TO PERFORMING ANY MAINTENANCE OR SERVICE.** Turning the mode selector switch to the OFF position **DOES NOT** disconnect power to controls or the unit itself.





**WARNING** When performing service, always ensure main power is disconnected from the unit. Do not rely on the Power On light. In the event of a burned out bulb, the Power On light may provide false indication that main power is disconnected.

 **WARNING** Whenever the nature of the operation permits, keep one hand away from the equipment to reduce the hazard of current flowing through vital organs of the body.

 **WARNING** Never work on electrical equipment unless there is someone nearby who is familiar with the operation and hazards of the equipment and is competent in administering first aid. When operators aid the technician, the technician must warn them about dangerous areas.

 **WARNING** Do not be misled by the term "low voltage" which may appear either within this manual or on enclosed drawings or documents. Electrical voltages as low as 50 volts may cause death under certain conditions.

 **WARNING** **DO NOT TOUCH** the hot system components. The design reactivation temperature range is 250° F to 300° F. The components of the reactivation system may be extremely hot during operation. Be absolutely certain that the unit and/or reactivation components are cool before attempting to work on any components.

 **CAUTION** Air intake and discharge openings must be free of obstructions. Ensure the filters are clean and the panels are on and properly secured.

 **CAUTION** Do not operate the unit without filters. It is better to operate the unit with dirty filters than with no filters. Operating the unit with no filters may void the warranty.

 **WARNING** The connection and service of gas components presents an extreme explosive hazard. Use the services of a qualified technician only.

 **WARNING** Blower motors may start unexpectedly when the unit is running due to an automatic resetting of the internal overload device.

 **WARNING** Do not allow anyone under the equipment while it's suspended from a lifting device.

 **WARNING** Do not allow the unit to swing while suspended from a lifting device. Failure to observe this warning may result in injury to personnel and damage to the equipment.

## 1.4 Product Warranty

### 1.4.1 Dehumidifier

Stulz Air Technology Systems, Inc. warrants to the original buyer of its products that the goods are free from defects in material and workmanship. Stulz Air Technology Systems, Inc.'s obligation under this warranty is to repair or replace, at its option, free of charge to the customer, any part or parts which are determined by Stulz Air Technology Systems Inc. to be defective for a period of 24 months from date of shipment when a completed start-up form has been submitted to Stulz Air Technology Systems, Inc. within 90 days from shipment. In the event that a completed start-up form is not received by Stulz Air Technology Systems, Inc. within 90 days from shipment, the company's obligation will be for a period of 12 months from date of shipment. Parts replaced under warranty are warranted for a period of 90 days from shipment or for the remainder of the Standard 1-year warranty period, whichever is greater.

Stulz Air Technology Systems, Inc.'s warranty does not cover failures caused by improper installation, abuse, misuse, misapplication, improper or lack of maintenance, negligence, accident, normal deterioration (including wear and tear), or the use of improper parts or improper repair.

Purchaser's remedies are limited to replacement or repair of non-conforming materials in accordance with the written warranty. This warranty does not include costs for transportation, costs for removal or reinstallation of equipment or labor for repairs or replacement made in the field.

If any sample was shown to the buyer, such sample was used merely to illustrate the general type and quality of the product, and not to represent that the equipment would necessarily conform to the sample.

This is the only warranty given by the seller, and such warranty is only given to buyers for commercial or industrial purposes. This warranty is not enforceable until the invoice(s) is paid in full.

THE FOREGOING SHALL CONSTITUTE SATS'S ENTIRE LIABILITY AND YOUR EXCLUSIVE REMEDY. IN NO EVENT SHALL SATS BE LIABLE FOR ANY DIRECT, INDIRECT, SPECIAL, INCIDENTAL, CONSEQUENTIAL, OR EXEMPLARY DAMAGES, INCLUDING LOST PROFITS (EVEN IF ADVISED OF THE POSSIBILITY THEREOF) ARISING IN ANY WAY OUT OF THE INSTALLATION, USE OR MAINTENANCE OF THE EQUIPMENT. THIS WARRANTY IS IN LIEU OF ALL OTHER WARRANTIES, EXPRESS OR IMPLIED, INCLUDING WARRANTIES OF MERCHANTABILITY OR FITNESS FOR A PARTICULAR PURPOSE.

### 1.4.2 Desiccant Rotor

Stulz Air Technology Systems, Inc. warrants to the original buyer of its *DESICAiR* products that silica gel desiccant dehumidification rotors are free from defects in material and workmanship. Stulz Air Technology Systems, Inc. specifically warrants the structural integrity of the desiccant element that it will not fail solely due to exposure to saturated (humid) air streams, subject to the conditions and exclusions set forth below. Stulz Air Technology Systems, Inc.'s sole obligation under this Limited Warranty is to repair or replace, at its option, free of charge to the customer (except as provided below), FOB factory, **for a period of 60 months from the date of shipment**, any rotor or rotor element determined by Stulz Air Technology Systems, Inc. to be defective.

Stulz Air Technology Systems, Inc.'s Limited Warranty does not cover defects, reduced performance or failures caused directly or indirectly by subjecting the rotor to conditions outside of manufactured operating parameters, improper installation, abuse, misuse, misapplication, improper maintenance, lack of maintenance, negligence, accident, normal deterioration (including wear and tear), or the use of improper parts or improper repair.

This warranty is invalid for applications other than water vapor dehumidification. Reduced performance or structural failure of the rotor element due to exposure to corrosive gases or liquids is excluded. Stulz Air Technology Systems, Inc. does not warrant the fitness of the equipment or its components to a specific application. The application of the equipment to a specific use is the sole responsibility of the user.

This Limited Warranty does not include costs for transportation (including, without limitation, freight and return freight charges, costs and insurance), costs for removal or re-installation of parts or equipment, premiums for overtime or labor for performing repairs, or replacements made in the field. Stulz Air Technology Systems, Inc. is not responsible for damages occurring during transport to or from Stulz Air Technology Systems, Inc.

THE OBLIGATION AND LIABILITY OF STULZ AIR TECHNOLOGY SYSTEMS, INC. UNDER THIS LIMITED WARRANTY DOES NOT INCLUDE LOSSES, DIRECT OR INDIRECT, FOR INCIDENTAL OR CONSEQUENTIAL DAMAGES. This limited warranty is provided exclusively to the original buyer of products and may not be assigned or otherwise transferred.

THIS LIMITED WARRANTY IS IN LIEU OF ALL OTHER WARRANTIES, EXPRESSED OR IMPLIED, INCLUDING WARRANTIES OF MERCHANTABILITY AND FITNESS FOR A PARTICULAR PURPOSE, AND THERE ARE NO WARRANTIES WHICH EXTEND BEYOND THE DESCRIPTION ON THE FACE HEREOF.

### 1.5 General Theory of Operation

This unit is designed to dehumidify a user-defined space or process to humidity levels that are below those attainable with a refrigeration-based system. Moisture is removed from the air through an adsorption process using a dry desiccant material that is impregnated to the desiccant rotor's fluted surface area. Air to be dehumidified (process air) is filtered, dehumidified, and supplied to the conditioned space at a lower relative humidity and a slightly higher dry bulb temperature than it's inlet condition.

Simultaneously a second air stream (reactivation air) is filtered, heated by the reactivation heater system and passed through a separate segment of the rotor. The heated air removes the previously adsorbed moisture from the desiccant in the rotor and exhausts it to an area other than that being conditioned.

During operation, the desiccant rotor continuously rotates at a constant speed through the process and reactivation sections of the dehumidifier. The two air streams are separated by face and peripheral seals, and by the internal fluting of the rotor. Process and reactivation airflows are counterflow to each other to maximize the efficiency of the adsorption process and to help prevent the rotor's flutes from fouling.

The reactivation heater is designed to raise the reactivation air temperature approximately 180° F above ambient. The energy from the heated air is used to desorb the moisture in the rotor. Reactivation discharge air temperature is approximately 100 to 150° F and moist. Controls are included in the unit to vary the amount of reactivation heat based upon the amount of moisture adsorbed from the process air stream

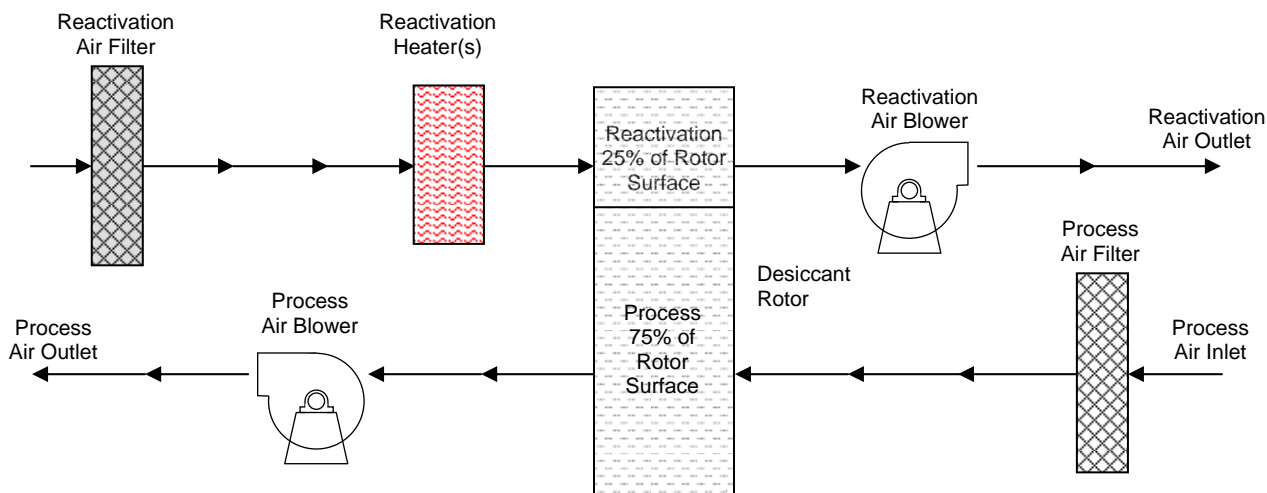

Figure 1 - General Theory of Operation

## 1.6 Construction

### 1.6.1 Cabinet

See Figure 2. This unit is self-contained in an aluminum cabinet rated for outdoor use. The mounting base has front and side entry forklift slots to facilitate moving and positioning the unit. The exterior of the cabinet is finished with a durable painted finish to protect it against corrosion. Access panels are provided for easy access to all major components for maintenance and/or service. The operator controls are conveniently located on the front of the unit. The cabinet houses the desiccant rotor assembly and drive system, process and reactivation air blowers, a reactivation heater system and electrical controls.

### 1.6.2 Inlets and Outlets

The two process air inlets and the process air outlet have round, flex duct connections. The reactivation air inlet and outlet have single rectangular openings and are equipped with louvers which aid in preventing rain or snow from entering. Screens are provided in the inlets and outlets to prevent birds or other small animals from entering or nesting. For the size and location of the duct connections, see the installation drawing provided with the unit.

The dehumidification system is equipped with manually adjusted process and reactivation

dampers for setting airflows to achieve the required pressure drops across the rotor (See Section 4.1.4 Monitoring Unit Performance).

Filtration is accomplished through the use of 30% pleated filters with aluminum roughing pre-filters located in the process and reactivation air inlets. The location of filter access panels are shown in the Installation drawing.

For a comprehensive list of the dehumidifier's features, refer to the DIN (Dehumidifier Identification Number) Sheet provided specifically for this unit. The DIN sheet provides a listing of all the features that are included. For particular detail of the features, refer to the installation and electrical drawings provided for the system.

### 1.6.3 Dehumidifier Identification Number

The Dehumidifier Identification Number (DIN) defines the specific features that are provided with the unit (see following page). The DIN Sheet for this unit is included for reference in a Technical Data Package. The Technical Data Package also contains a Technical Data Sheet, a Test Report (showing performance information), Drawings and this Manual. A manual for the system controller is also included under separate cover. These documents should be stored in a safe place on or near the unit for reference.

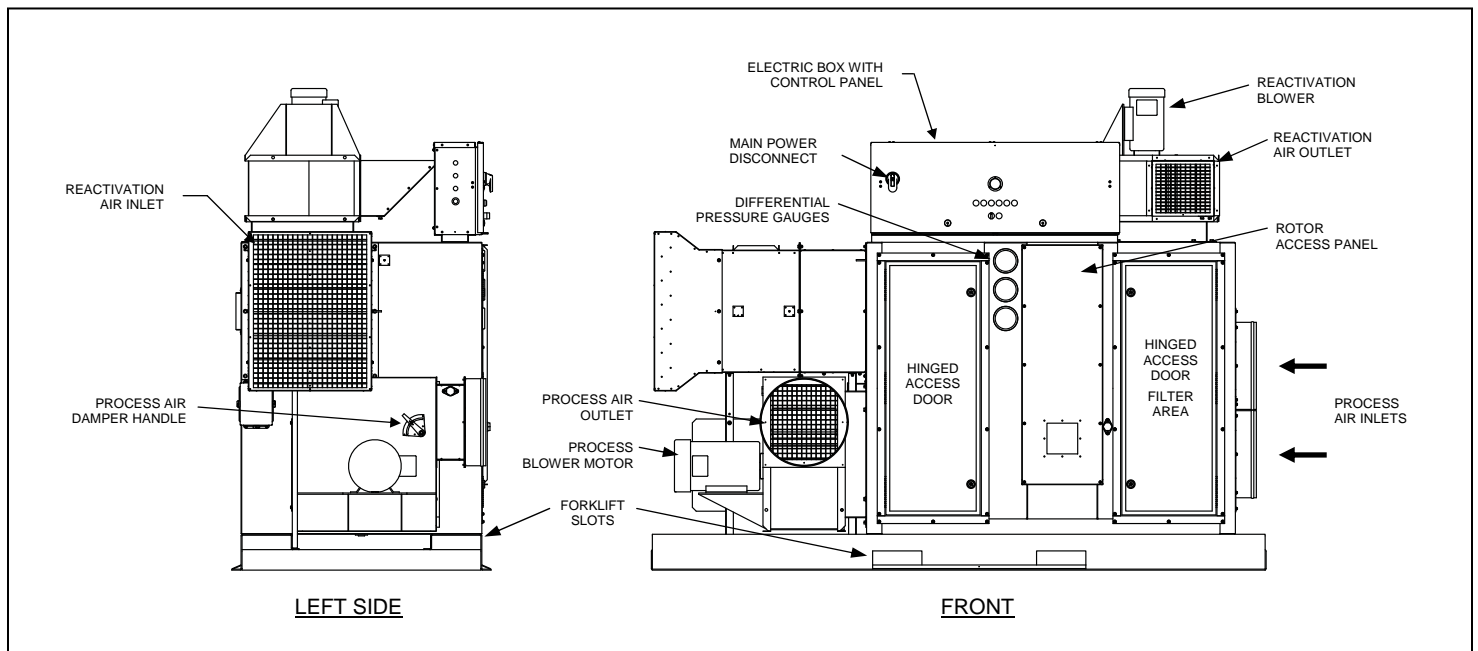

**Figure 2 - General Layout**  
(SD2-5000-96-G Shown For Reference)

**SD2 Series 2900 Dehumidifier Identification Number (DIN) Sheet**

The Dehumidifier Identification Number (DIN) starts with the model number cfm/rotor diameter combination (ex. SD2-3000-77). The first 23 digits after the model number (represented by the uppercase letters A-V below) pertain to the cabinet construction, rotor, and process and reactivation accessories or options.

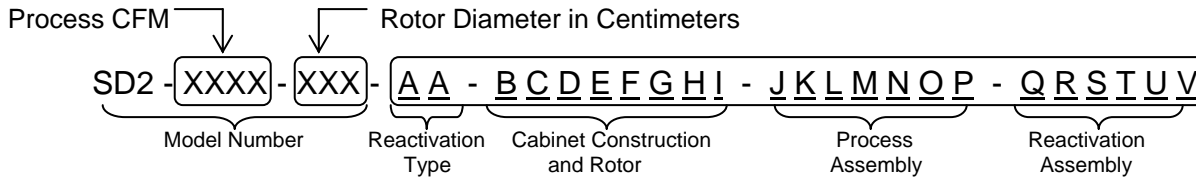

The last 25 numbers (represented by lowercase letters a-v) pertain to the electrical system, unit controls, the power supply, control scheme, and the control panel.

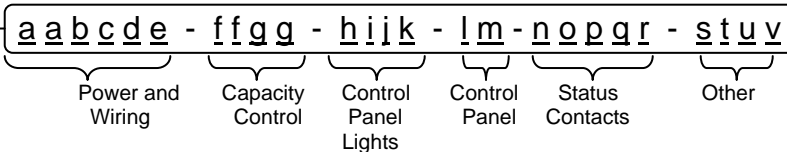

The following is a sample DIN Sheet for a *DESICAIr* SD2 Series 2900 Desiccant Dehumidifier

**DESICAIr DEHUMIDIFIER SPECIFICATION REVIEW**

Date: xx/xx/xx

DEHUMIDIFIER IDENTIFICATION NUMBER

SD2-3000-77-07-04099110-9636111-362391-021321-0100-0000-21-00000-1101

Project:  
SATS Job #

Cabinet construction, rotor, process and reactivation assemblies:

|        |                                  |                                               |
|--------|----------------------------------|-----------------------------------------------|
| A - 07 | Reactivation Heater:             | Direct Propane Gas- Industrial                |
| B - 0  | Unit Configuration:              | Left-hand: View Proc. In - Access on Left     |
| C - 4  | Cabinet Construction:            | Portable- Single Wall Aluminum                |
| D - 0  | Insulation:                      | None                                          |
| E - 9  | Paint:                           | # 286 From Pantone Chart                      |
| F - 9  | Mounting:                        | Portable- 4 Way Slots w/ Aluminum Skid & Cage |
| G - 1  | Rotor:                           | Standard                                      |
| H - 1  | Rotor Drive Motor:               | Standard: TENV                                |
| I - 0  | Food Grade Materials:            | No                                            |
| J - 9  | Process Inlet:                   | Round flex duct - Rental dia.                 |
| K - 6  | Process Inlet Filters:           | Roughing & 30% w/gauge & Flag                 |
| L - 3  | Process Outlet:                  | Round Flex duct w/damper & Screen             |
| M - 6  | Process Blower Size Range:       | DES Flow @ 600 FPM thru rotor                 |
| N - 1  | Process Blower Orientation:      | Standard- Horizontal Front                    |
| O - 1  | Blower Isolation:                | Standard: DD-none / BD-rubber                 |
| P - 1  | Process Blower Motor:            | Standard efficiency, TEFC                     |
| Q - 3  | Reactivation Inlet:              | Louver                                        |
| R - 6  | Reactivation Inlet Filters:      | Roughing & 30% w/gauge & Flag                 |
| S - 2  | Reactivation Outlet:             | Weather Hood w/screen                         |
| T - 3  | Reactivation Blower:             | Flow @ 600 FPM thru rotor                     |
| U - 9  | Reactivation Blower Orientation: | Top Mount- Discharge to Front                 |
| V - 1  | Reactivation Blower Motor:       | Standard efficiency, TEFC                     |

Electrical system, power supply, control scheme, and control panel:

|        |                                  |                                       |
|--------|----------------------------------|---------------------------------------|
| a - 02 | Power Supply:                    | 208/1/60                              |
| b - 1  | Elect. End. & Wiring:            | STD: NEMA-4 box, Liquid Tight conduit |
| c - 2  | Disconnect:                      | Fused                                 |
| d - 2  | Electrical Enclosure Heater:     | -40 Deg F ambient                     |
| e - 1  | Control Panel (Op Station/MMI):  | Standard: Mtd on elect. enclosure     |
| f - 01 | Capacity Control:                | D-Stat                                |
| g - 00 | Sensor/Transmitter:              | By others                             |
| h - 0  | Dirty Filter Indicator Light:    | None                                  |
| i - 0  | Process Air Proving Light:       | No                                    |
| j - 0  | React Air Proving Light:         | No                                    |
| k - 0  | Digital Display of RH or Dew Pt: | No                                    |
| l - 2  | Overheat Reset P-button:         | Externally-mtd on elect. enclosure    |
| m - 1  | Press-to-Test Lights:            | Yes                                   |
| n - 0  | Start/Stop Dry Contact:          | No                                    |
| o - 0  | Dirty Filter Contact:            | No                                    |
| p - 0  | Process Air Proving Contact:     | No                                    |
| q - 0  | React Air Proving Contact:       | No                                    |
| r - 0  | Summary Fault Contact:           | No                                    |
| s - 1  | Phase/Voltage Monitor:           | Yes                                   |
| t - 1  | Emergency STOP P-button:         | Yes                                   |
| u - 0  | Retransmit Sensor Value:         | No                                    |
| v - 1  | Rotor Rotation Detection:        | Yes                                   |

**Additional Features Included in this Unit:**

Unit Dimensions to be 51" Wide      Unit to include Lifting eyes/lugs

Skid and Cage to be Aluminum Construction

Electric Panel & Disconnect relocated to meet unit dimensions and accessibility

Reactivation Air Filters to be Accessible From Top of unit for easy removal

Unit to include Cam Lock power inlets. SEE ATTACHED LIST OF RECEPTACLES AND CAPS

## 2.0 INSTALLATION

### 2.1 Receipt of the Unit

Upon receiving the *DESICAiR* desiccant dehumidification unit, immediately inspect the unit for damage which may have occurred during shipment. Carefully remove the shipping cover and protective packaging. If any damage is found, report it to the carrier immediately. **Any obvious damage incurred during shipping must be noted on the freight carrier's delivery forms BEFORE signing for the equipment. Freight claims must be done through the freight carrier.** Generally, all equipment ships "F.O.B. Factory". SATS can assist in the claim filing process with the freight company.

Open the access doors, remove any loose parts, and check the equipment against the packing list to see if the shipment is complete. Report all discrepancies to the appropriate authority.

### 2.2 Rigging

The dehumidifier is designed to be kept in a level position. Move the unit with a suitable device such as a forklift or attach an overhead lifting sling to the unit, supporting it from beneath the mounting base or the skid rails if provided. Use an appropriate capacity lifting device to ensure that it can safely handle the weight of the unit. Weight tables are provided on the installation drawing. If using an overhead lifting device, utilize lifting bars that exceed the cabinet width so as to avoid crushing the sides of the unit and/or damaging the components mounted to the sides.

 **WARNING** Do not allow the unit to swing while suspended from a lifting device. Failure to observe this warning may result in injury and damage to the equipment.

### 2.3 System Location and Clearance

Allow unrestricted access to the dehumidifier to perform routine inspection and maintenance. The recommended minimum clearance on the front side of the unit is the full width of the cabinet plus space for necessary equipment (forklift, lifting device, etc.).

To judge the clearance requirements, consider that all the components are housed inside the *DESICAiR* dehumidifier cabinet. The desiccant rotor is typically the largest component requiring removal, although blower assemblies, while somewhat smaller, also require sufficient clearance for removal.

 **WARNING** The leaving reactivation air can be very warm and humid. Keep items that may be damaged by excessive heat and humidity away from the reactivation air outlet.

Position the unit in the desired location. Make sure the mounting surface is able to support the weight of the equipment and keep it level. Secure the unit to the mounting surface. Mounting holes may be drilled into the base of the unit for anchoring it. The following general requirements should also be considered:

- 1) The power source should be located as near as possible to the installed location of the equipment.
- 2) Provisions should be made to ensure that power is not accidentally disconnected during normal operation and that the power disconnect switch is not used to turn off the unit for normal shut-down.
- 3) If possible, avoid locations where the air intakes will be laden with dust, dirt, soot, smoke, or other debris.

 **CAUTION** DO NOT operate the unit in or near flammable or corrosive environments or allow flammable or corrosive air into the unit.

- 4) Refer to the wiring diagram for electrical connections.

## 2.4 Connecting Ductwork

Ducting should be sized for the appropriate air quantity and pressure drop. The clearance required for the duct connections depends on whether the unit is to be ducted for process air, reactivation air, or both. Refer to the installation drawing for the duct connection locations.

When installing the system outside the conditioned space, the process air outlet and both process air inlets must be ducted to and from the conditioned space to prevent humid air from entering the process air stream.

When installing the system in the conditioned space, the reactivation air inlet and outlet must be ducted to and from another area to prevent warm, moist air from being returned to the conditioned space.

The reactivation air temperature at the outlet will be warm (approximately 120° F) and humid. If duct work is connected to the reactivation outlet, it should be insulated and sloped down and away from the unit. This will prevent condensed moisture from accumulating at the reactivation outlet.

**NOTE:** Flow regulation dampers are provided with this unit. After all ductwork is installed, refer to Section 4.1.4, Monitoring Unit Performance for using the dampers to set the correct process and reactivation air volumes. If air volumes are not set correctly, the unit's performance may be affected.

All ducting must be air-tight or the dehumidification system will not perform to its maximum capability. Even small leaks can have a dramatic effect on system performance.

Ensure the inlets and outlets are free of obstructions and the filters are kept clean.

## 2.5 Utility Connections

### 2.5.1 Power Hookup

Main power is supplied to the system through customer provided, main power cables equipped with Cam-Lok® plugs. Four male panel receptacles are furnished on the electric box to connect the power cables. Only Cam-Lok series connectors can be used to mate with these panel receptacles.

This system is provided with a main power disconnect switch. The disconnect switch (circuit breaker) provides branch circuit protection and allows power to be removed for installation, maintenance or service functions. Use caution when servicing the unit. For wiring details, refer to the electrical drawing provided.



**WARNING HIGH VOLTAGE IS USED IN THE OPERATION OF THIS UNIT.** Use the services of a QUALIFIED ELECTRICIAN ONLY to make the electrical power connections.

1. Refer to the electrical drawing for the main power connections.
2. Connect power to the main disconnect per the electrical drawing for this unit. See the unit nameplate (mounted near the electrical control box) for the minimum circuit ampacity (MCA) and maximum fuse size (MFS) for determining the appropriate wire gauge.

### 2.5.2 Gas Connections

Have your local gas company connect the gas supply line if applicable (natural or propane, as specified on the unit nameplate), making sure it is adequately sized for the required Btu/hr (also on the nameplate). The required design inlet gas pressure is 10" to 14" w.c., or as defined on the unit nameplate. Do not exceed the maximum gas pressure shown. Refer to the Gas Flow drawing provided for more detail on the gas connections.



**WARNING DO NOT** interchange natural and propane gas on a gas-fired unit. Use only the type of gas specified on the nameplate.

## 2.6 Installing a Humidistat or RH Transmitter

A terminal block is provided for the connection of a humidity control sensor, (humidistat or temperature/RH transmitter). Wire the control sensor per the electrical drawing provided with your unit. Interconnecting field wiring must be installed in accordance with NFPA 70 of the National Electrical Code (N.E.C.).

Wall-mounted control devices should typically be mounted 4-5 feet up from the floor in the conditioned space (see Figure 3 below).

Locate the sensor according to the application. To control the conditions in a space, a wall mounted sensor may be used in the space or a duct mounted sensor may be located in the return air inlet duct if the air is re-circulated. To control the air supplying a process, a duct mounted sensor may be located in the supply air duct near the process. Duct mounted sensors cannot be used for D-Stat control but can be used for control schemes where the process blower runs continuously, such as D-Stat II control (see Section 3.5, Capacity Control).

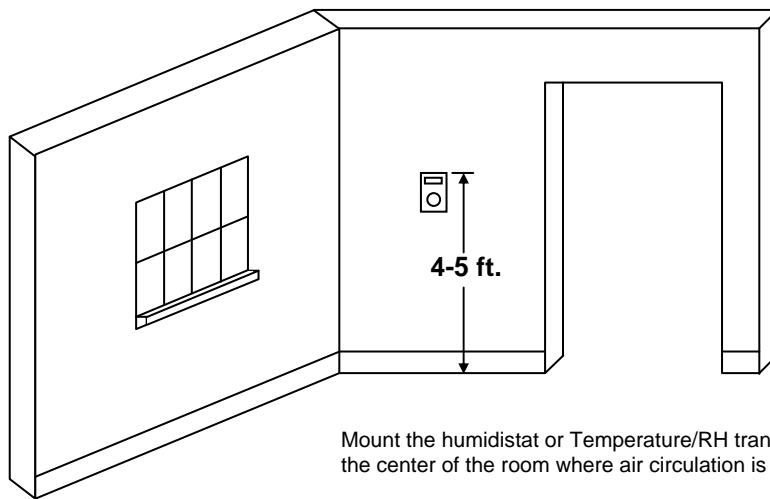

Mount the humidistat or Temperature/RH transmitter in the center of the room where air circulation is good.

**Figure 3 - Locating Wall-Mounted Control Sensor**

### 3.0 OPERATION

The following information provides an overview of the operating procedures and sequences. Before operating the unit, go through the checklist below to make sure all electrical and utility connections are correct and the unit is ready for operation.

**NOTE:** A Warranty Registration and Start-Up Checklist is provided in the data package supplied with your unit. It should be completed during installation and a copy should be sent to SATS (Attn: Product Support). It will assist if service or troubleshooting support is needed.

#### 3.1 Installation Checks

Using the Warranty Registration and Start-Up Checklist forms, record the steps taken during installation. Recommended tools for performing the pre-operation checkout include a voltage meter with temperature probe, a flashlight, a phillips and flathead screwdriver, and a digital amp meter.

1. Verify the main power per the unit nameplate. **ONLY USE POWER THAT'S RATED FOR THIS UNIT PER THE NAMEPLATE. INCORRECT POWER MAY DAMAGE THE UNIT AND CAUSE DAMAGE TO PROPERTY OR INJURY OR DEATH TO PERSONNEL.**
2. Check all electrical connections for tightness.
3. If the unit operation is dual voltage (208/230), ensure the Voltage Monitor (KR32) and Primary Control Transformer (T1) are configured correctly for the applied voltage as depicted in the diagram located on each component.
4. Check the transformer secondary voltage.
5. Check the wiring to any remote sensors, humidistat, start/stop switch, etc. Refer to the electrical drawing for specific wiring connections.
6. For gas fired units, ensure all burner fuel valves and/or gas cocks on the unit are closed.
7. For gas reactivation, turn on the source supply (gas) and verify the pressure is correct per the unit nameplate. For gas units, make sure all lines are purged of air.
8. Ensure no loose parts or spare parts (such as extra filters, etc.) are located inside the unit or the electric box.
9. Ensure all access doors are closed tight. Small air leaks can significantly reduce unit performance.

#### 3.2 Start-Up

1. Apply main power to the unit and turn the "On/Off" mode selector switch to ON. Ensure the rotation of all motors (process, reactivation, and rotor drive motor) are as indicated by the arrow labels on or near the motors.
2. Set airflows to the required rotor pressure drop versus the airflow required for this application. Airflow is indicated by rotor pressure drop values as viewed on the differential pressure gauges mounted on the unit. Refer to the Technical Data Sheets provided with the unit for the optimum "Reactivation Side" and "Process Side" pressure drops (*Rot. Press. Drop, in. w.c.*). Using dampers, set the process and reactivation airflows to establish the rotor pressure drops at the values indicated. Set the airflows while the unit is still cold. Refer to Section 4.1.3, Monitoring Unit Performance for more details on setting and monitoring airflows.

**NOTE:** During basic unit operation, process air will enter one side of the unit cool and humid and leave the other side of the unit warm and dry. Reactivation air will enter one side of the unit cool and will leave the other side very warm and moist.

3. Verify that amp draws of each component are within  $\pm 10\%$  of the ratings shown on the unit nameplate.
4. Ensure the operation of the heater controls and gas train assembly components (if applicable). Refer to Section 3.3 for details on starting gas units.
5. Verify the operation of all switches and safeties. The green "Unit On" and red "Status Indication" lights are equipped with "press-to-test" capability. Use this feature to test operation of the lamp element. If a "press-to-test" light does not illuminate when pressed, it may be burned out or the electrical connections may be faulty.
6. Depending on the control methodology, set the humidity or dewpoint to the desired setting with the system controller.
7. Insert a temperature probe into the temperature test ports to verify the reactivation temperature entering the rotor (varies up to 190° F above ambient). Also verify the reactivation temperature leaving the rotor (130° - 150° F at full output).

8. Verify the grain depression across the system (in the process air stream) is correct per the Technical Data Sheet.

### 3.3 Initial Start-Up for Gas Fired Units

#### 3.3.1 Gas Train Ignition Sequence

There are several important parts to an industrial gas unit. On the gas train itself is a pilot solenoid valve, two main gas solenoid valves, a main gas regulator and pilot gas regulator, a gas control valve/actuator and several hand valves. The burner assembly consists of a spark ignitor, a flame rod (to detect a flame), and the burner. Inside the electric box is a burner control relay module (see Figure 4).

Refer to the source manufacturers wiring diagram provided for the burner control relay module. Applying power on terminals L1 and L2 of the burner control relay module provides power to the electronic network.

The burner control relay module initiates the ignition sequence with a pre-purge cycle. Following the pre-purge cycle, the pilot solenoid opens and the ignition transformer is energized. Refer to the burner control relay module source manufacturer's information for the ignition sequence (provided separately).

The unit is equipped with a High/Low Gas Pressure Switch (S20). If the gas supply pressure is not within the limits of the switch, the Check Air/Gas indicator light illuminates and the burner control relay module will not allow the burner to light or operate.

Failure to establish a pilot flame during a limited ignition trial cycle causes the pilot valve to de-energize and stop electric ignition. The burner control relay module remains locked out until a manual reset occurs.

**Note:** The safety lockout requires a manual reset. See Figure 4 for the location of the reset button.

If the flame rod senses a flame, it signals the flame control relay module, which opens the main gas solenoid valves (V21 & V22). The system controller determines how much heat is required to achieve setpoint and modulates the gas valve actuator (AT20) accordingly.

Flame failure during operation de-energizes the fuel valves and the gas control circuit automatically goes into a new purge and then an ignition trial cycle one more time.

Power interruption to the burner control relay module de-energizes relays and valves. The main gas and pilot solenoid valves close immediately. The modulating gas control valve actuator is spring-return and also closes when the unit loses power.

Once power is restored, the timer motor completes its cycle plus another safe-start check, complete purge and new ignition trial.

#### 3.3.2 Gas Burner System Start-Up

**NOTE:** The gas burner is set up and adjusted when the unit is tested prior to leaving the factory.

*For initial system start-up:*

 **CAUTION** DO NOT interchange natural and propane gas on a gas-fired unit. Only use the type of gas specified on the nameplate.

1. Ensure that the gas supply line is purged of all air up to the main gas connection on the unit. Several ignition trials/resets may be required to purge the gas line up to the burner.
2. Inspect the flame to ensure the burner produces an even, blue flame along its entire length at minimum and maximum output.
3. If the burner won't ignite after several trials or the flame isn't evenly distributed, see Section 3.3.3 for burner setup/adjustment instructions

#### 3.3.3 Gas Burner Set-Up/ Adjustment

If the gas burner won't ignite or the flame is uneven or yellow, the burner may need to be readjusted. This may be because the gas supply quality or pressure varies as compared to the SATS gas supply used for testing.

Before making adjustments, review Section 3.3.1 for a full understanding of the ignition sequence.

 **WARNING:** The connection and service of gas components presents an explosion hazard. Initial burner start-up and adjustments should only be performed by qualified technicians who are trained to work with combustion systems.

1. Prior to supplying main gas to the dehumidifier, gas pressure must be checked to ensure it doesn't exceed the maximum inlet pressure shown on the unit nameplate.

2. Check that all dampers are properly positioned and locked into the operating position.
3. Start the unit with all hand operated gas valves closed. Check for proper motor rotation and impeller direction. Ensure the gas burner differential pressure gauge reads between 0.7" w.c. and 1.3" w.c.
4. Turn the unit off before proceeding to step 5.

**CAUTION** Do not bypass any control panel timers which typically control sequential operation.

5. To light and adjust the gas pilot: Open the Main Gas Supply Shut-off Valve and open the Pilot Gas Shut-off Valve (see Figure 6). Start the unit and ensure the pilot indicator light illuminates (see Figure 4). Observe the pilot flame through the burner viewing window.
6. If ignition doesn't occur the first time, it may be necessary to reset the burner control relay module. Several ignition trials/resets may be required to purge the gas line up to the pilot.

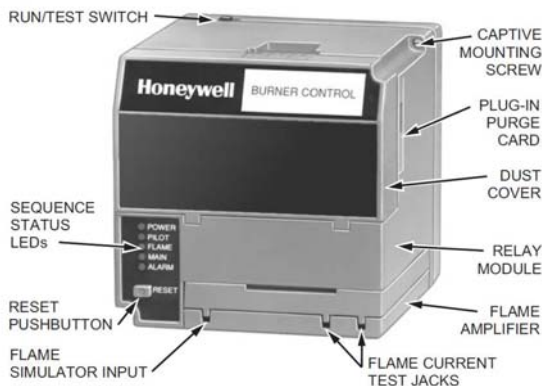
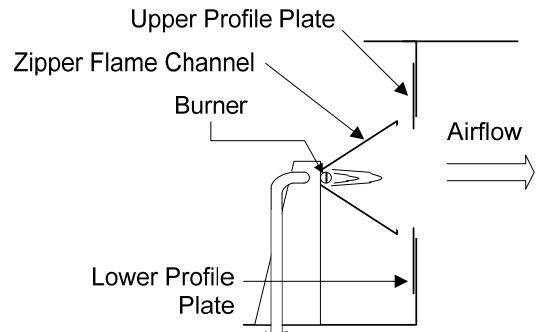

**Figure 4 - Burner Control Relay Module**

7. Refine the pilot setting for a hard blue flame by adjusting the gas flow through the Pilot Gas Adjustment Needle Valve and/or Pilot Gas Regulator.
8. Prepare to light the main burner flame. Using the system controller, manually adjust the Gas Modulating Control Valve to the minimum position by varying the analog output signal. Refer to the system controller IOM for information on adjusting the output signal.
9. With the Gas Modulating Control Valve at "minimum", light the main burner by gradually opening the Main Burner Gas Shut-off valve. Adjust the Main Gas Regulator to provide the desired outlet pressure. A good minimum fire should provide a uniform blue flame across the

entire burner, which is contained within the zipper flame channel (see Figure 5).

10. Close the Main Gas Balancing Valve. Using the system controller, manually adjust the output signal to the Gas Modulating Control Valve to the maximum output position. Open the Main Gas Balancing Valve gradually and adjust it to limit the gas flow so the reactivation air temperature doesn't exceed the design temperature. Adjust the Main Gas Regulator and the Upper and Lower Profile plates as required to obtain an even blue flame.
11. After the reactivation heater temperature approaches equilibrium, manually adjust the Main Gas Balancing Valve to limit the minimum burner output to achieve a reactivation air temperature rise of approximately 180° F above the reactivation inlet air temperature.
12. Any thin spots or gaps indicate uneven air velocity over the burner and must be corrected by re-adjusting the burner profile plates to provide an even air flow across the top and bottom of the burner. Re-adjust the Upper and Lower profile plates together with the reactivation outlet damper to achieve the correct burner and reactivation differential pressures (in. w.c.) as indicated on the Technical Data Sheet provided with the unit. Burner and reactivation static pressures are displayed on the unit's differential pressure gauges.
13. Shut off the unit then start it again. The burner should light quickly after the pre-purge time delay.



**Figure 5 - Burner Assembly**

14. Tighten the set screw on the Main Gas Balancing Valve to lock its position. Cycle the unit on & off several times and verify the burner ignites each time. Return control of the Modulating Gas Control Valve to automatic operation.

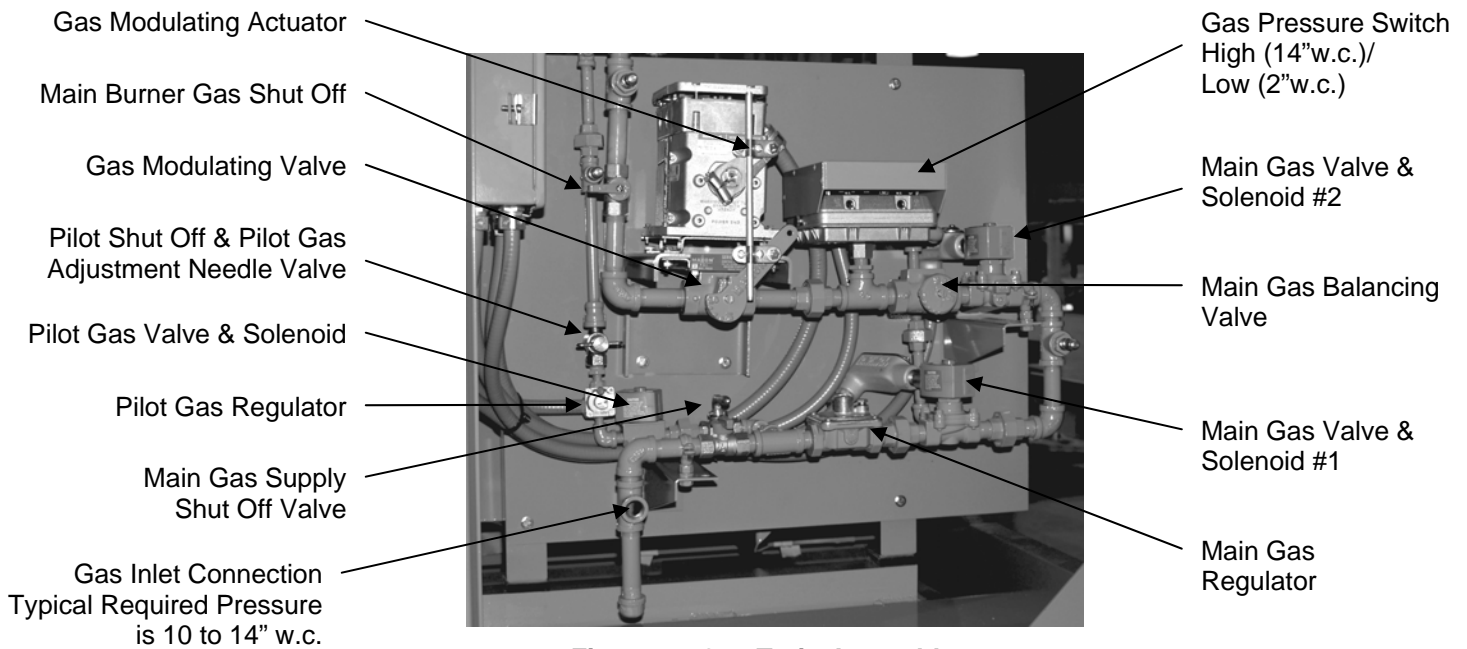

Figure 6 - Gas Train Assembly

### 3.4 System Controller

This unit is equipped with a solid state microprocessor based controller mounted inside the electric box. Generally, this device is used to modulate the reactivation heater to maintain the reactivation discharge air temperature setpoint of 120 to 140° F at the reactivation air outlet. The controller automatically modulates reactivation heat to maximize drying capacity.

The controller is shipped from the factory pre-programmed. The source manufacturer's operating manual for the controller is provided under separate cover. Refer to the source manufacturer's instructions for detailed information on operating the controller and adjusting control parameters.

### 3.5 Capacity Control

There are two basic control methods for SD2 Series 2900 dehumidifiers: 1) **D-Stat**, 2) **D-Stat II**. The way in which your unit operates depends upon which features are purchased for your unit. Refer to your order sheet or DIN Sheet for specific details on the control method selected for your unit.

#### 3.5.1 D-Stat

What it Does:

This control cycles the dehumidifier on and off to maintain the relative humidity setting.

Requires:

A wall-mounted control sensor (humidistat) or a dry contact to enable remote start/stop.

How it Works:

The dehumidifier responds to a control signal from a humidistat (provided as an option) or a customer-supplied dry contact control signal to cycle the unit on and off to maintain the relative humidity setting.

The unit shuts down when the relative humidity of the conditioned space is less than the relative humidity setting minus differential. The mode selector switch (S15) must be set to ON.

Conditions:

Sensor control range: 15 to 90% RH  
 Ambient range: 40° to 125° F  
 Space control accuracy: +/-7% RH

**D-Stat II**

How it Works:

This control functions similar to D-Stat, except the process blower runs continually. The reactivation heater and blower cycle on and off in response to a humidistat or a customer-supplied dry contact (Remote Start/Stop contact).

Conditions:

Sensor control range: 15% to 90% RH

Ambient range: 40° to 125° F

Space control accuracy: +/-7% RH

---

**NOTE:** D-Stat and D-Stat II will not work without a humidistat or a customer supplied signal (dry contact closure).

---

**3.6 Reactivation Types**

Reactivation heat is controlled during operation to maintain the reactivation discharge (leaving) air temperature, generally between 120° to 140° F. The temperature of the reactivation air entering the rotor is about 180° F above ambient (depending upon the moisture load of the reactivation air and/or the flow rate of the reactivation air).

There are two basic reactivation types for Series 2900 dehumidifier units: Electric and Gas-fired. Refer to the electrical drawing provided with your unit for detail on the heater circuit. The general theory for each reactivation type is described below:

**3.6.1 Electric Reactivation**

Electric heat is generated by an SSR (solid state relay) controlled heater or SCR (silicon controlled rectifier) controlled heater. The SSR cycles the heater on and off to maintain the reactivation discharge air temperature based upon a signal it receives from the system controller. SCR's also receive a signal from the system controller, but modulate the percentage of energy output for tighter control.

There may be more than one heater bank depending upon the capacity required. Refer to the Electrical drawing for details.

To prevent high "in-rush" currents during starting, the reactivation starting sequence is delayed. Once the process blower starts, the reactivation blower and heater banks start as needed.

**3.6.2 Direct Gas-fired Reactivation**

The gas supplied for a direct-fired unit may be natural or propane, as specified on the unit nameplate. In a direct-fired unit, the burner is mounted in the reactivation air stream. The ignition sequence is controlled by a UL/FM/CSA approved Burner control relay module (see Figure 4). Piping details can be found on the Gas Flow Diagram provided with your unit.

The system controller modulates a gas valve to regulate the amount of gas reaching the burner, thereby maintaining the reactivation discharge air temperature.



**WARNING** DO NOT interchange natural and propane gas on any gas-fired unit. Use only the type of gas specified on the unit nameplate.

### 3.7 Control Panel

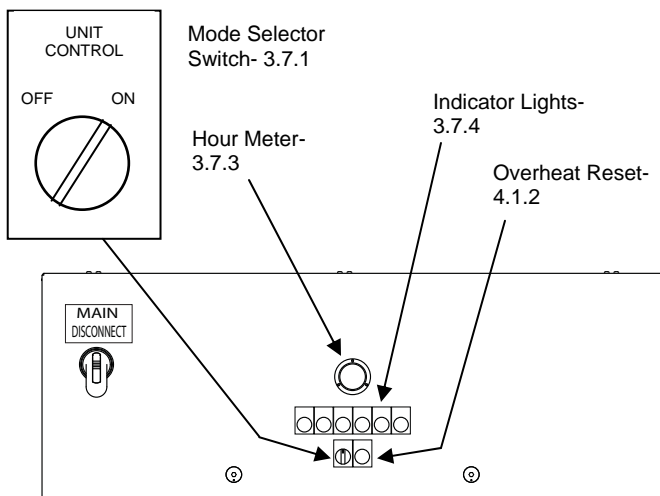

Figure 7 - Control Panel

#### 3.7.1 Mode Selector Switch

The Series 2900 unit is equipped with a two (2) position selector switch (ON/OFF) located on the front of the unit. Refer to the table below for the basic modes of operation:

| Mode | Status of Unit                                                                                              |
|------|-------------------------------------------------------------------------------------------------------------|
| OFF  | Unit is off, power is still live if main disconnect is ON; white "Power On" indicator light is illuminated. |
| ON   | Unit is on and runs continuously; green "Unit On" indicator light is illuminated.                           |

**NOTE:** The unit will not operate in the ON mode if a humidistat is installed (and the contact is open) or the appropriate jumper connection is not made on the unit terminal block to enable remote start/stop control of the dehumidifier. Refer to the electrical diagram for specific wiring connections.

**NOTE:** The reactivation blower and the rotor will continue to run for five (5) minutes after the unit cycles off to remove residual heat from the unit.

#### 3.7.2 Sample Nameplate

For information about operating voltage for this unit, refer to the nameplate located near the electrical control box. A sample nameplate is shown in Figure 9. The unit nameplate provides technical operating information along with the model number, serial number and specific Stulz Air Technology Systems job number. This information will be required if it is necessary to contact SATS for additional information, warranty information, or spare parts.

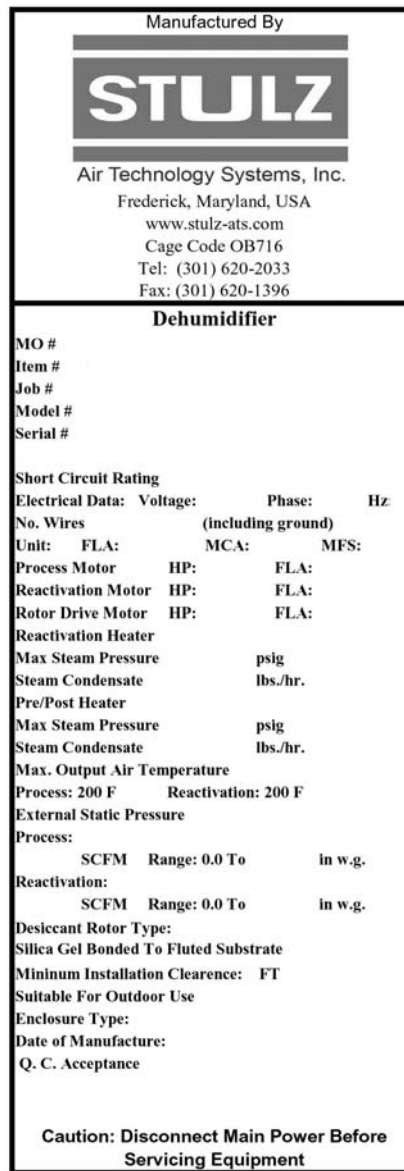



Figure 8 - Sample SATS Nameplate

#### 3.7.3 Hour Meter

An hour meter, located on the control box door, gives the elapsed run time for purposes of scheduling maintenance.

### 3.7.4 Control Panel Lights

Each unit is equipped with visual indication lights to notify the operator of the current status of the unit. The green "Unit On" and optional, red status indicator lights are equipped with "Press to Test" capability. This should be used to test operation of the lamp element. If a light does not illuminate when pressed, it may be burned out or the electrical connections may be faulty. Certain status indicator lights may operate together with optional customer interface contact terminals (see Section 5.0, Optional Features). For specific information regarding troubleshooting fault lights, refer to the Section 7.0 of this manual.

The "light"  next to the indicator light name specifies its color.

W = White

R = Red

G = Green

Refer to the Electrical drawing for details.

#### Standard Indication Lights

##### POWER ON

This illuminates white when main power is supplied to the unit.

##### UNIT ON

This illuminates green when main power is supplied to the unit and the unit is running.

##### HIGH REACTIVATION TEMPERATURE

This illuminates red and the heater shuts off when the reactivation air temperature entering leaving the rotor is above the high temperature limit. A manual reset of the Overheat Safety Switch (S22) is necessary.

#### Gas-fired Units Only

##### BURNER FAULT

This illuminates red when the flame rod does not detect a flame or there has been no ignition of the burner. A manual reset of KR20 is necessary (located in the electrical enclosure). Refer to Figure 5.

##### CHECK AIR/GAS FAULT

This illuminates red when the air proving switch has detected insufficient airflow or when the gas pressure is not within the desired range (high or low). This automatically resets when the Air/Gas fault is remedied.

### 3.7.5 Optional Status Indication Lights

The unit may be equipped with optional status indication lights. Refer to the DIN sheet provided with the unit for the unique characteristics of your unit and the optional features that are included.

##### DIRTY FILTER(S)

This illuminates red when the filters must be changed. There may be more than one filter indication light depending upon whether a light is assigned for process filters, reactivation filters, or both.

##### ROTOR ROTATION FAULT

This illuminates red if the unit determines the rotor has not made a complete revolution within a defined period of time.

##### PHASE /VOLTAGE FAULT

This illuminates red in the event of an incorrect phase sequence, loss of a single phase, low voltage, or a voltage unbalance. The voltage monitor relay (used on 1 phase units) and the phase monitor relay (used on 3 phase units) cause control power to be interrupted. This ensures the protection of the unit's motors. An automatic reset occurs when the fault condition is corrected (see Section 5.1.3, Voltage Sensor/Phase Monitor).

## 4.0 UNIT FEATURES

### 4.1.1 Control Sensor Terminals

This unit is equipped with terminal positions for the connection of a customer installed control device, such as a humidistat, for operating the selected control scheme (see Section 3.5, Capacity Control).

In general, the control device (i.e. humidistat) signals the controller to start the reactivation heater. The unit maintains space humidity to the setting made on the device. Refer to the electrical drawing for details on interfacing the control sensor/transmitter with the equipment.

### 4.1.2 Overheat Reset Push Button

This push button (S22) located on the control panel door, is used to reset the unit when the "High Reactivation Temperature" light illuminates (see Section 3.7.4, Control Panel Lights).

**! CAUTION** Determine the cause of the overheat condition prior to resetting the unit. For example, check the condition of the filters and the system airflow, as indicated by rotor pressure drops (see Section 4.1.4, Monitoring Unit Performance).

### 4.1.3 Dampers

This unit is equipped with manually adjustable air dampers for the process air stream and reactivation air stream. The dampers are slide/locking style, and are located adjacent to the duct transitions. The dampers are used to adjust the process and reactivation air flows to meet design conditions for optimal unit performance. The dampers are to be readjusted after installation of the ductwork is complete. Refer to Section 4.1.4, Monitoring Unit Performance.

### 4.1.4 Monitoring Unit Performance

Two differential pressure gauges are provided to indicate the pressure drops across the desiccant rotor (see Figure 9). Rotor pressure drop (static pressure) correlates directly to airflow. In order to maintain optimum performance, process and reactivation airflows should be set to the recommended rotor pressure drops. Refer to the Technical Data Sheet included with the unit to determine the appropriate values for the rotor pressure drops (inches w.c.).

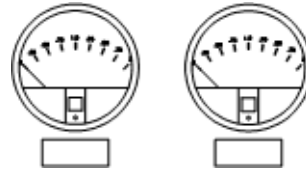

**Figure 9 - Differential Pressure Gauges**

After all ductwork is installed during initial installation, the airflows may need to be adjusted to re-establish rotor pressure drops to the values indicated on the Technical Data Sheet.

Set the airflows by adjusting the process and reactivation air dampers while the unit is still cold. The air dampers (provided optionally) are generally located in the process and reactivation air outlets.

Afterward, if the differential pressure gauges show readings that are significantly lower than the initial factory settings, there may be an obstruction or the filters may need to be changed. Operating the unit with dirty filters will reduce the performance of the unit. Never operate the unit without filters as this may damage the desiccant rotor.

### 4.1.5 Reactivation Air Proving Switch

A Reactivation Air Proving Switch (S14) is provided as a safety feature. The reactivation heater is interlocked by the reactivation air proving switch. The switch contacts close when there is sufficient reactivation airflow. The switch contacts will open upon loss of reactivation airflow, de-energizing the reactivation heater. When the airflow problem is corrected, the heater will automatically resume normal operation.

### 4.1.6 Test Ports

Test ports are conveniently located at strategic points before and after the desiccant rotor in the process and reactivation air streams. These test ports are equipped with 1" NPT threaded stubs which are capped off during normal operation. The test ports allow for measurement probes to be inserted for monitoring the temperature or humidity conditions within the unit while it's operating.

## 5.0 OPTIONAL FEATURES

This unit may be equipped with one or more of the following optional features. For a detailed list of the features purchased with this unit, refer to the Dehumidifier Identification Number (DIN) sheet provided with the unit. The DIN number for this unit can be found on the DIN sheet.

### 5.1.1 Burner Gauge

If Gas is used for reactivation, a separate differential pressure gauge is provided to monitor the pressure drop across the burner. For optimal performance, the burner gauge reading should be between 0.7" w.c. and 1.3" w.c. The burner pressure drop is pre-set at the factory and should not require adjustment.

### 5.1.2 Filter Gauges

The unit may be provided with optional, differential pressure gauges for the filters that are selected. These differential pressure gauges may be used to monitor the condition of the filters for maintenance purposes.

*The differential pressure value below indicates the change-out value for the filters:*

30% Pleated w/ Aluminum Pre-Filter ..... 1.0" w.c.

When a filter gauge shows the maximum value listed above, the filter should be changed. Operating the unit with dirty filters may reduce performance and/or damage the rotor. DO NOT operate the unit without filters. It is better to operate the unit with dirty filters than with no filters. Continuously operating the unit with dirty filters or with no filters may void the warranty.

### 5.1.3 Voltage Sensor/ Phase Monitor

This unit may be equipped with either a voltage sensor or a phase monitoring device located in the electric box. A voltage sensor (used on single phase units) causes the control power to be interrupted in the event of low line voltage. A phase monitor (used on 3 phase units) causes control power to be interrupted in the event of an incorrect phase sequence, loss of a single phase, low voltage, or voltage unbalance. This protects the unit's motors. An automatic reset occurs when the fault condition is corrected. An LED on the sensing/monitoring device illuminates to indicate that operating conditions are normal.

### 5.1.4 Emergency Stop

This unit may be equipped with an optional emergency stop push button switch mounted on the control panel. In an emergency the button may be pressed to disconnect control power from the unit to cease operation. To restore power, twist the switch button to release it and it will return to the normal position. If the unit is equipped with a main disconnect circuit breaker, this must be reset also.

**NOTE:** The emergency stop switch disconnects power from the unit contactors causing them to open. Main power is still present in the unit when the emergency stop switch is pressed.

### 5.1.5 Electrical Disconnect

This unit may be equipped with a "through-the-door" main power disconnect switch located on the door of the electric box. The "Power On" light should illuminate white when the switch is in the ON position. The switch allows power to be removed during maintenance or service functions. The handle of the switch is equipped with a lockout feature to prevent unauthorized actuation during periods of service or maintenance. If a disconnect switch is NOT provided, the unit will have power when the electrical connections to the main power receptacles are made. Use caution when servicing the unit. For wiring details, refer to the electrical drawing provided with the unit.



**WARNING** Even with the electrical disconnect switch in the "OFF" position, incoming power may still be "live" between the disconnect switch and the main power source. Power must be disconnected from the main source before servicing.

### 5.1.6 Spare Rotor Belt

This unit may be equipped with a spare rotor drive belt mounted to the rotor ring adjacent to the peripheral seal. This simplifies the belt removal and new belt installation steps that are discussed in the Repair Procedures section. To change belts, follow steps 1 – 4 of Section 8.2, Belt Removal Instructions. Cut the old belt to remove it or fasten it to the rotor ring like the spare belt. Remove the clamp securing the spare belt and slide the belt over the rotor and onto rotor drive timing pulley. Restore tension by positioning the tensioner pulley on the belt.

### 5.1.7 Electrical Enclosure Heater

This unit may be equipped with an electrical enclosure heater to prevent damage to or malfunction of the controls. When the temperature in the control panel drops below a pre-determined level, the heater will energize and when it rises above a pre-determined level, the heater will de-energize. For wiring details, refer to the electrical drawing supplied with the unit.

### 5.1.8 Customer Interface Terminals

This unit may be equipped with optional customer interface terminal positions located on terminal block TB3 in the electrical enclosure. The terminals may be used for remote monitoring and control purposes. Certain status contacts may operate together with assigned status indicator lights. Refer to the unit DIN sheet to determine which status contacts and indicator lights are provided with this unit.

**NOTE:** Refer to the electrical drawing for specific ratings of the contacts and for wiring details

#### *ROTOR ROTATION FAULT CONTACT*

This contact closes when the unit determines that the rotor has not made a complete revolution within a defined period of time.

#### *PROCESS BLOWER INTERLOCK CONTACT*

This *dry* contact closes when the process blower is on. It can be used to indicate unit operating status or to start and stop auxiliary equipment such as a circulating fan or condensing unit.

### 5.1.9 Auxiliary Control Terminals

This unit may be equipped with optional customer control interface positions located on terminal blocks in the electrical enclosure. For the wiring connections, refer to the electrical drawing provided.

#### *REMOTE START STOP CONTACT*

Terminal positions may be provided to connect a remotely operated "Start/Stop" control device. It may be used to start and stop the unit independent of the systems controls when the mode selector switch is in the "On" position. When the circuit is closed the unit will start operating; when opened the unit will stop operating (after the purge cycle). Refer to the electrical drawing for wiring details.

**NOTE:** The unit will not start if the space humidity is below the setting on the humidistat.

## 6.0 PREVENTIVE MAINTENANCE

Minimal periodic Preventive Maintenance Checks and Services (PMCS) are recommended to ensure utmost performance of the *DESICAiR* Series 2900 dehumidification unit. Routine maintenance can correct deficiencies before they cause serious damage to the equipment and helps ensure that the unit is ready for operation at all times.

A schedule for preventive maintenance inspection and service should be established immediately after installation of the unit. A system should be established to record any problems, defects, and deficiencies noted by operators and discovered during maintenance inspections, together with the corrective actions taken. Use copies of the Periodic General Maintenance Checklist in Appendix A to record maintenance inspections. For assistance, contact SATS Product Support.

The following lists the preventive maintenance checks and services that should be performed and the recommended intervals. When operating under extreme or unusual conditions, such as a very dusty or sandy environment, it may be necessary to reduce the maintenance intervals indicated. The schedule below assumes that your system operates continuously.



**WARNING** When performing service, always ensure main power is disconnected from the unit. Do not rely on the Power On light. In the event of a burned out bulb, the Power On light may provide false indication that main power is disconnected.



**WARNING** Turning the “On/Off” unit selector switch (S15) to the OFF position DOES NOT disconnect power.

### 6.1 Monthly

- Check all electrical connections to ensure they are tight and not shorted to ground.
- Ensure the control panel lights are functional and not burned out (use the “Press to Test” feature).
- Remove, clean, and/or replace the filters to ensure proper airflow through the unit. If your environment is exceptionally dusty or sandy, this may be required on a more frequent basis.

- Inspect the flame on gas units. It should be clean and blue as described in steps 9 and 10 of Section 3.3.3, Gas Burner System Start-Up.
- Check the rotor seals for wear and ensure the seals are touching the rotor face and rotor flange.
- Check the rotor drive belt for signs of abnormal wear.
- Check the blower belts (if applicable) for signs of abnormal wear.
- Lubricate motor bearings if necessary.
- Ensure the pillow block bearing shaft set screws are tight if applicable.
- Ensure the shaft key, pulley and bearing lockdowns are tight if applicable.

### 6.2 Yearly

- Thoroughly clean the unit inside and out, making sure to remove any dust from fan blades and dirt buildup on the rotor and in the ductwork (see Section 8.4.3, Rotor Cleaning).

### 6.3 Desiccant Rotor Drive Motor Maintenance

A speed reducing gearmotor is used to rotate the desiccant rotor. The gearmotor bearings are pre-lubricated and do not require re-lubrication. Periodically inspect around the gearmotor for accumulated dirt and remove by vacuuming. **Dirt accumulation can cause motor heating and is a fire hazard.** Also observe the motor while operating for high motor current, unusual noises or vibration, overheating, worn or loose couplings and belts or loose mounting bolts

### 6.4 Blower Motor Maintenance

#### 6.4.1 General Inspection

Inspect the blower motors at regular intervals (approximately every 550 hours of operation or every 3 months). Keep the motors clean and make sure the ventilation openings are clear. The steps listed below should be performed at each inspection.



**WARNING** Voltages used with this unit can be deadly. Use the services of a qualified electrician and/or technician to make the electrical power connections and perform maintenance.

1. Ensure the motor is clean. Check to make sure the interior and exterior of the motor are free of dirt, oil, grease, water, etc. because these things can accumulate and block motor ventilation. If the motor is not properly ventilated, overheating can occur and cause early motor failure.
2. Use a "Megger" periodically to verify the integrity of the winding insulation and record the readings. If there is a significant drop in insulation resistance, immediately investigate.
3. Ensure all electrical connections are tight.

### 6.4.2 Lubrication & Bearings

The lubricating ability of bearing grease depends primarily on the type of grease, the size of the bearing, the speed at which the bearing operates and the severity of the operating conditions. This lubricating ability can be lost over time. For motors that require periodic service, the following recommended lubrication interval and procedure should be followed.

1. A high grade ball or roller bearing grease should be used. Several recommended greases for standard service conditions are Shell Dolium R (factory installed), Texaco Polystar, Amoco Rykon Premium #2 or Chevron SRI#2.
2. Lubrication should be performed at the recommended intervals shown in the table below. These recommended intervals are based on average use. See nameplate on motor for frame size and rated speed.

**NOTE:** Some motors are provided permanently lubricated and will not require service for the lifetime of the equipment.

**Table 1 - Lubrication Intervals**

| NEMA/IEC Frame Size         | Rated Speed - RPM |            |
|-----------------------------|-------------------|------------|
|                             | 3600              | 1800       |
| Up to 210 incl. (132)       | 5500 Hrs.         | 12000 Hrs. |
| Over 210 to 280 incl. (180) | 3600 Hrs.         | 9500 Hrs.  |
| Over 280                    | 2200 Hrs          | 7400 Hrs.  |

**Table 2 - Service Conditions**

| Severity of Service | Ambient Temperature Maximum  | Atmospheric Contamination             | Type of Bearing          |
|---------------------|------------------------------|---------------------------------------|--------------------------|
| Standard            | 40°C                         | Clean, Little Corrosion               | Deep Groove Ball Bearing |
| Severe              | 50°C                         | Moderate dirt, Corrosion              | Ball Thrust, Roller      |
| Extreme             | >50°C* or Class H Insulation | Severe dirt, Abrasive dust, Corrosion | All Bearings             |
| Low Temperature     | <-30°C**                     |                                       |                          |

\*Special high temperature grease is recommended (Dow Corning DC44 or Darmex 707).

\*\*Special low temperature grease is recommended (Aeroshell 7).

**Table 3 - Lubrication Interval Multiplier**

| Severity of Service | Multiplier |
|---------------------|------------|
| Standard            | 1.0        |
| Severe              | 0.5        |
| Extreme             | 0.1        |

**Table 4 - Bearing Sizes and Types**

| Frame Size<br>NEMA (IEC)       | Bearing Description (These are the “Large” bearings (shaft End) in each frame size) |          |             |                                             |                                 |          |
|--------------------------------|-------------------------------------------------------------------------------------|----------|-------------|---------------------------------------------|---------------------------------|----------|
|                                | Bearing                                                                             | OD<br>mm | Width<br>mm | Weight of<br>Grease to<br>add oz<br>(grams) | Volume of grease to<br>be added |          |
|                                |                                                                                     |          |             |                                             | in <sup>3</sup>                 | teaspoon |
| Up to 210 incl. (132)          | 6307                                                                                | 80       | 21          | 0.30 (8.4)                                  | 0.6                             | 2.0      |
| Over 210 to 280 incl.<br>(180) | 6311                                                                                | 120      | 29          | 0.61 (17.4)                                 | 1.2                             | 3.9      |
| Over 280                       | 6313                                                                                | 140      | 33          | 0.81 (23.1)                                 | 1.5                             | 5.2      |

**Sample Lubrication Determination**

Assume NEMA 286T (IEC 180), 1750 RPM motor driving an exhaust fan in an ambient temperature of 43°C and an atmosphere that is moderately corrosive.

1. Table 1 lists 9500 hrs for standard conditions.
2. Table 2 classifies severity of service as “Severe”.
3. Table 3 lists a multiplier of 0.5 for severe conditions.
4. Table 4 shows 1.2 in<sup>3</sup> or 3.9 teaspoons of grease to be added.

**6.4.3 Lubrication Procedure**

Be sure that the grease you are adding is compatible with the grease already in the motor. Consult the factory or the motor manufacturer if you are using a grease other than the recommended type.

**! CAUTION** To avoid damage to motor bearings, keep grease free of dirt. If you have an extremely dirty environment, contact the factory or the motor manufacturer for additional information.

1. Clean the grease fitting.
2. If motor has a grease outlet plug, remove it.
3. If the motor is stopped, slowly add the recommended amount of grease. If the motor is to be greased while running, add a slightly greater quantity of grease.
4. Add grease slowly until new grease appears at shaft hole in the endplate or purge outlet plug.
5. Re-install grease outlet plug if removed.

## 7.0 TROUBLESHOOTING

The *DESICAIr* dehumidifier is designed for continuous and dependable operation. An overheat fault circuit and air proving switch is built into the reactivation air path to detect high reactivation air temperature or loss of airflow.

The following guidelines are included to assist you in troubleshooting the dehumidifier due to operational or performance problems. Refer to the electrical and installation drawings provided with your unit for the location of the system components and their relationship to each other. If the problem can't be resolved using the guidelines below, contact SATS Product Support for assistance (see Section 9.0).

---

**NOTE:** The High Reactivation Temperature safety could trip if the main power is disconnected from the unit while it is running. Before disconnecting main power, turn the dehumidifier "On/Off" mode selector switch to the "OFF" position and wait five (5) minutes until the reactivation time delay shuts off the reactivation blower.

---

### Problem: Unit Does Not Run

If the dehumidifier is controlled by a remote mounted device such as a humidistat, check this device before you check the dehumidifier itself.

In the ON mode:

1. Check the humidistat and the system controller.
2. Check the power supply for correct voltage and phase. The unit is equipped with a voltage monitor which prevents damage to electrical components that can be caused by improper voltage. Adjustments may be necessary to ensure the device functions properly.
3. Check wiring connections. Refer to the electrical diagram included with your unit.
4. Check fuses and replace if necessary.
5. Check the motor thermal overloads or circuit controllers.

### Problem: Dehumidifier Performance is Reduced

This condition could indicate a problem with the dehumidifier or a change in moisture loads within the space which is being conditioned. Refer to the performance curves in Appendix B to verify the performance conditions are as stated.

It is important that the power supply voltage and phase be correct and that the airflow rate be adjusted to the correct values.

1. To check the dehumidifier performance, take dry bulb and wet bulb temperature measurements upstream and downstream of the desiccant rotor in the process air stream. Convert the readings to grains per pound. Compare the results to those indicated by the Technical Data Sheet. If the results are comparable, the problem is not with the unit. In this case, analysis of the entire "system" of duct work and the space including any changes in moisture loads (occupancy etc.) is required.
2. Ensure the fans are rotating in the correct direction. If they are reversed, turn the unit off, allow for the cool down cycle. Check the motor wiring against the diagrams shown on the motor nameplate to ensure it matches the phase and voltage shown on the dehumidifier nameplate (see Figure 8). If the unit is 3 phase, simply switch any two power supply leads at the power distribution block. If the unit is single phase, reconnect the wires according to the motor nameplate diagram.
3. Check the process and reactivation airflows. See Section 4.1.4, Monitoring Unit Performance.

---

**NOTE:** The desiccant itself is designed for a ten year life with little degradation over time (<10% over 10 years).

---

4. Improperly filtered air or oil-contaminated air can affect the capacity of the desiccant. If this is the case, performance may be restored by washing the rotor as described in Section 8.4, Rotor Cleaning Instructions.
5. Check the rotor seals. Ensure the seals are intact and that the edge seal makes contact with the rotor perimeter to prevent air from leaking.
6. Check for air leakage. Inspect the exterior of the system cabinet, check the door seals and duct connections to ensure there are no air

leaks. Open the access doors and inspect the interior of the cabinet for signs of possible leaks in the plenums and transition ducts.

If the result of rechecking is unsatisfactory, call DESICAiR Product Support.

Problem: Reactivation Heater Not Operating, Yet Blower Is On

1. Check heater fuses (Electric Reactivation Only).
2. Reactivation Air Proving Fault. Inadequate airflow condition across the reactivation section of the rotor.
  - a. Ensure there are no physical obstructions in the reactivation inlet or outlet.
  - b. Ensure the filters are clean and in good condition.
  - c. Ensure the reactivation discharge damper is adjusted to provide the proper pressure drop across the desiccant rotor (refer to Section 4.1.4, Monitoring Unit Performance and the Technical Data Sheet provided with your unit or contact the factory for the correct setting).
  - d. Ensure the reactivation air proving switch (S14) is adjusted correctly\*. This switch is located behind the reactivation differential pressure gauge. The switch may need to be adjusted depending on altitude.

\*The air proving switch is typically set to trip at 2/3's of the designed reactivation air pressure drop. Refer to the Technical Data Sheet provided or contact the factory for the correct setting.

Example: if the pressure drop setting is 1.5", then the switch should be set to open at 1.0".

Problem: Process Blower Does Not Turn, Yet "Unit On" Lamp is Illuminated

1. Check the motor thermal overload and/or fuses for the process blower.
  - a. Reset if necessary.
  - b. Identify and correct the cause of the overload condition.

In this case, amp draw of the motor exceeded the design condition.

With main power off, check that the blower turns freely. Also, check the blower motor fuses, ensure no shorts are present and ensure all wire connections tight.

With main power on, start the unit and ensure the process fan damper is adjusted to provide the proper pressure drop across the desiccant rotor (refer to the Technical Data Sheet or contact the factory).

Problem: Reactivation Blower Does Not Turn, Yet "Unit On" Lamp is Illuminated

1. Check the motor thermal overload and/or Circuit Controller (CT2) for the reactivation blower.
  - a. Reset if necessary.
  - b. Identify and correct the cause of the overload condition.

In this case, amp draw of the motor exceeded the design condition.

With main power off, check that the blower turns freely. Also, ensure all wire connections tight and no shorts are present.

With main power on, start the unit and ensure the reactivation fan damper is adjusted to provide the proper pressure drop across the desiccant rotor (refer to the Technical Data Sheet or contact the factory for the correct settings).

- c. Ensure the overload current setting on (CT2) matches the motor data plate FLA for the rated voltage. Adjust (CT2) if necessary.

---

**NOTE:** With D-Stat II capacity control, the reactivation blower and desiccant rotor do not run if humidity conditions are satisfied.

---

Problem: Desiccant Rotor Does Not Turn, Yet "Unit On" Lamp is Illuminated

1. Check the motor thermal overload and/or Circuit Controller (CT1) for the rotor drive motor.
  - a. Reset if necessary.
  - b. Identify and correct the cause of the overload condition.

In this case, amp draw of the motor exceeded the design condition.

With main power off, ensure the belt and tensioner are properly positioned. Realign the belt or reset the tensioner if necessary. Check the seals for improper adjustment or wear. If the seals aren't properly adjusted or if the surface is worn through, increased drag will occur. This may cause

increased power draw or too much torque for the motor.

- c. Ensure the overload current setting on (CT1) matches the motor data plate FLA for the rated voltage. Adjust (CT1) if necessary.

## 7.1 Troubleshooting Fault Lamps

A Fault indication can result from a number of fault conditions including a motor fault, high reactivation temperature condition, rotor rotation fault or air proving fault. To correct the fault condition, ensure the airflows are sufficient. Refer to Section 4.1.4, Monitoring Unit Performance for information on setting and verifying the correct airflow. Ensure all filters are clean, check for obstructions in unit or ductwork and check the rotor drive belt.

Check the other status indicator lamps and status contacts, if the unit is so equipped, for troubleshooting a specific fault. Refer to the following troubleshooting guidelines (i.e. High Reactivation Temperature Lamp On), for corrective action for fault condition(s) that are observed.

### Problem: "High Reactivation Temperature" Lamp is Illuminated

Indicates a high temperature condition in either the reactivation heater section (above 350/425° F) or the reactivation discharge air temperature is above 175° F. Allow at least 10 seconds for the blowers to cool the unit then press the red Overheat Reset Button (S22) on the control enclosure door. This fault will automatically reset without pressing S22 if power is removed from the unit.

To prevent this problem from recurring, verify that reactivation air volume is sufficient. Ensure the reactivation inlet, reactivation outlet and the ductwork are not obstructed or damaged. Ensure the filters are clean and unclogged, the rotor flutes are not dirty (clogged) and the reactivation discharge air damper is in the proper position. Referring to Section 4.1.4, Monitoring Unit Performance and the Technical Data Sheet provided with your unit, ensure there is proper pressure drop across the desiccant rotor by adjusting the reactivation discharge damper if necessary.

For gas-fired units, ensure there are no mechanical failures in the gas train and the main gas balancing valve (see Figure 6) is locked down and has not been tampered with. Contact the

factory for instructions on adjusting or repairing gas train components.

A High Reactivation Temperature fault can also occur if either sensor (thermocouple) connected to an overheat safety switch (S21-1 or S21-2) is malfunctioning.

### Problem: "Check Air/Gas" Fault Lamp Illuminated

#### (Gas Fired Reactivation Only)

This indicates either an improper burner pressure drop setting or a high/low pressure condition. Ensure the burner pressure drop is approximately 1.0" by adjusting the burner profile plates both above and below the gas burner, if necessary. Refer to Figure 5, Burner Assembly. The profile plates should be adjusted so that an even airflow distribution is maintained across both the upper and lower sections of the burner. Ensure that the inlet gas pressure is between 2" and 14" WC. If gas inlet pressure is within the limits, both switch contacts will be closed (this can be checked through the small view windows on the gas pressure switch (S20) located on the gas train. Ensure that the burner air proving switch (S14) is adjusted correctly\* (switch is located behind the burner pressure differential gauge). This switch may need to be adjusted depending on altitude.

\*Air Switches are typically set to trip at 2/3's of the measured pressure drop (example: if the pressure drop setting is 1.5", then the switch should be set to open at 1.0").

Problem: "Burner" Fault Lamp

Illuminates Continuously

**(Gas Fired Reactivation Only)**

This could indicate several different problems. If the burner pilot lights then immediately goes out, and the Burner Fault indicator is illuminated, this may indicate a malfunctioning flame rod. If the ignition cycle starts, the burner pilot does not light, and the Burner Fault indicator is illuminated, this indicates either a malfunctioning ignition circuit or an improper pilot gas pressure/volume adjustment. Ensure all air is purged out of the gas line supplying the dehumidifier.

The pilot should be adjusted to provide the minimum amount of gas required to ensure a clean flame and light consistently. The Pilot flame should not extend beyond the burner. If adjustments to the pilot train do not correct the problem, the spark igniter may need to be replaced. A burner fault will have to be manually reset with the button located on the lower left corner of the burner control relay module (see Figure 4). Please contact the factory for instructions on repairing or adjusting gas train components.

---

**NOTE: Cold Weather Operation**

Gas fired units may experience problems when temperatures fall below 32° F. The vaporization rate for LP gas decreases in direct proportion to the ambient temperature. This condition can cause improper ignition, improper flame characteristics, or lowered Reactivation temperatures. Keeping the LP tank temperature elevated will help correct this condition.

---

Problem: "Phase/Voltage" Fault Lamp Illuminated

This indicates either a high/low voltage condition or a phase reversal (3 phase units) condition. It is imperative that the actual supply voltage correspond with the required voltage indicated on the unit nameplate. Verify the phase voltage before making any adjustments to the voltage monitor. If the unit is designed for 3 phase operation, ensure the phasing is correct. Voltage monitor configurations and settings may vary; please consult the factory for assistance with your specific unit.

Problem: "Rotor Rotation" Fault Lamp Illuminated

This indicates that the desiccant rotor is not rotating properly. Ensure that the rotor belt is intact and that the tension is correct. Ensure that the desiccant drive motor overload (CT1/OL1), if installed, is not tripped. Also ensure that the limit switch (S19) is functioning properly and making contact with the 'trip block' every revolution.

## 8.0 REPAIR PROCEDURES

Under normal operating conditions and with the proper preventive maintenance, the unit should provide excellent service for many years. If necessary, the unit may be returned to the manufacturer or a suitably qualified depot for major overhaul and refurbishment. All work must be performed by qualified technicians and should include replacement of rotor, seals, motors, starters, contactors, bearings and other accessories as necessary.

### 8.1 General Rotor Handling Guidelines

When performing maintenance on the rotor, please observe the following guidelines:

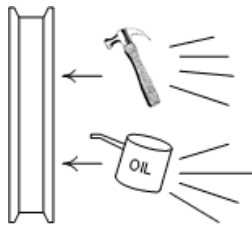

DO NOT STRIKE ROTOR

1. DO NOT strike the surface of the rotor or allow any objects to strike the surface which may cause damage to the shell and the fluted ceramic desiccant media.

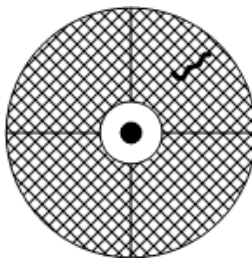

DO NOT SCRATCH ROTOR

2. DO NOT allow the surface of the rotor to become scratched. Use caution around the rotor when working with any tools that could cause scratches to the surface.

**NOTE:** If damage DOES occur to the face of the rotor, refer to the Rotor Repair Section 8.5 or contact SATS Product Support at (888) 529-1266 for repair assistance.

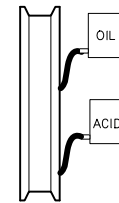

AVOID CONTACT WITH PAINT, OIL, ACIDS, ETC.

3. DO NOT allow the rotor to come into contact with paint, oil, acids, etc.
4. DO NOT allow dirt, dust, or debris to settle into the rotor element. Follow rotor washing instructions if the rotor has been subjected to long periods of storage in extreme conditions.
5. DO NOT subject the rotor to vibration.

### 8.2 Drive Belt Replacement

The following instructions for removing and replacing the drive belt for the rotor are in sequential order. Do not skip or rearrange the steps listed below when replacing the belt. Refer to Figure 10 for details of the rotor assembly parts.

Before replacing the belt, read the instructions below. Make sure the tools listed below are available and that power has been disconnected. Check the new belt to ensure it is free from cracks, rips, tears or other defects.

The following tools are necessary for removal of the belt:

- Rubber mallet
- One large phillips-head screwdriver
- One large flat-head type screwdriver
- A utility (razor) knife
- Small swivel mirror
- Flashlight
- One tube of RTV silicone sealant and a caulking gun
- Wrenches (box end and socket) 5/16", 3/8" & 7/16" (avoid open-end wrenches because they can slip off the head of the screw causing damage to the rotor)
- Socket wrench extension (minimum 2" long)
- One 4 x 4 block of wood, approx. 8" long
- One 2 x 4 piece of wood, 36" - 48" long
- A standard business card
- Wax paper sheet, approximately 1ft<sup>2</sup>

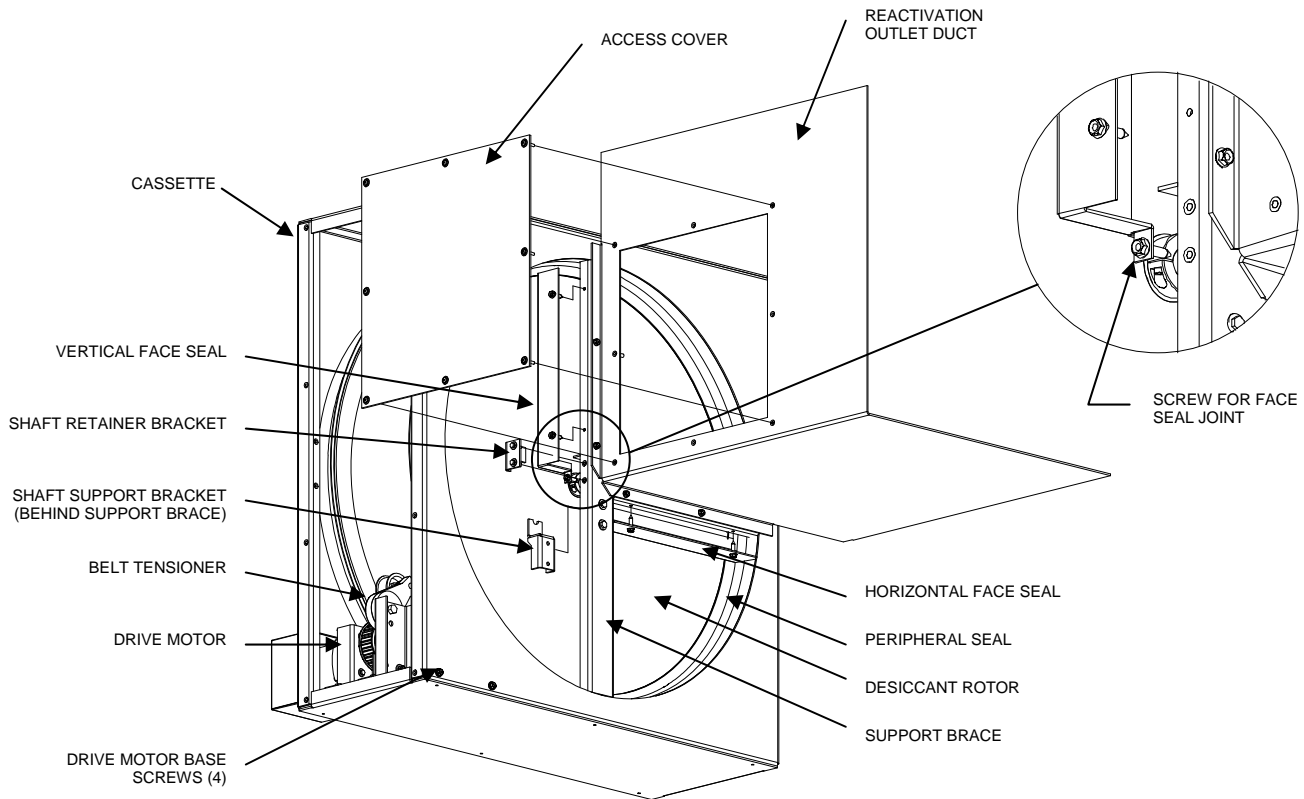
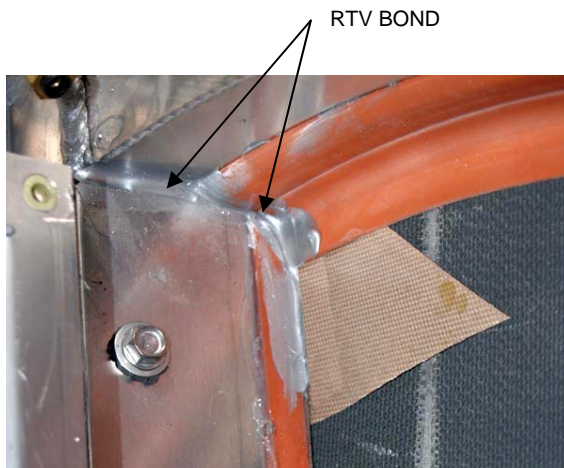

Figure 10 - Rotor Assembly Parts

### 8.2.1 Removing the Old Belt

1. Allow the reactivation blower and rotor to run for 5 or more minutes to remove residual heat from the unit. Then disconnect all power to the unit. Turning the mode selector switch to the "Off" position DOES NOT disconnect power to the unit. Do not attempt to change the belt if the rotor or reactivation portion of the unit is warm.
2. Open the cabinet access doors on both sides of the rotor. Refer to the installation drawing for the location of the correct access doors.
3. Remove the desiccant rotor access panel from the cabinet (held in place with phillips head screws). Set the panel and screws aside.
4. Remove the access cover from the reactivation outlet duct (held in place with phillips head screws).
5. Remove the belt from the tensioner (near the drive motor). Pull the arm of the tensioner towards you to release the tension then, slip the belt off the drive wheel of the motor. The belt should now hang free on the rotor.
6. Remove the four hex screws (two on each side of the cassette) holding the rotor drive motor base. Disconnect the wires from the motor. Remove the motor and tensioner assembly from the cabinet and set it aside.
7. Remove the hex screws holding the shaft retainer brackets (both sides of rotor). Set the brackets and screws aside.
8. Remove the hex screws that secure the horizontal and vertical face seals in place between the reactivation outlet duct and the surface of the rotor. Then using a 7/16" socket wrench with a 2" socket extension, remove the screw for the face seal joint. This screw is difficult to see as it's situated between the rotor surface and the vertical support brace. It can only be accessed after removing the shaft retainer bracket. It is helpful to use a flashlight with a small swivel mirror to locate the screw head.

9. After all the face seal screws are removed, locate the point where the vertical and horizontal face seals meet the peripheral seal (see Figure 11). This union has been joined together with RTV silicone sealant. Using a razor utility knife, CAREFULLY break the RTV bond only. Use caution to avoid cutting through the peripheral seal or the rotor surface.



**Figure 11 - Face/Peripheral Seal Union**

You should now be able to slide the face seals past the surface of the rotor and remove them.

10. Refer to Figure 12. From the end of the cassette (where the motor was located), place a 4 x 4 wood block on the floor of the cabinet. Place it under the same side of the rotor that you removed the face seals from. Position it underneath the angled, edge support flange that runs around the perimeter of the rotor.
11. Next, wedge a 2 x 4 between the 4 x 4 and the edge of the angled support flange to raise the rotor. Make sure the 2 x 4 does not lift the rotor at the center, away from the angled support flange or the rotor will be damaged. Apply leverage to slightly raise the rotor. Only raise the rotor enough to take the weight off the rotor shaft support bracket on the side of the rotor that you removed the face seals from (no more than 1/8"). Raising it too high may damage the rotor surface and mounting hardware on the opposite side.

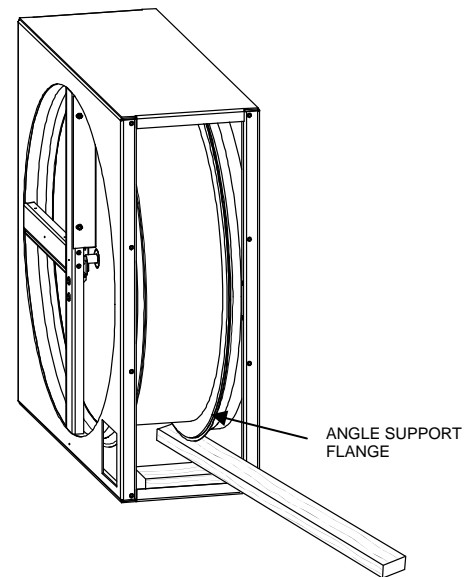

**Figure 12 - Raising the Rotor**

12. Secure the 2 x 4 by wedging it between the rotor's angled support flange and the 4 x 4.
13. Remove the rotor shaft support bracket on the side of the rotor that you removed the face seals from.
14. Next, carefully remove the old belt using your fingers and/or a non-metallic rounded object (like a pencil). Work the belt out through the peripheral seal and towards the reactivation outlet duct. Take care not to damage the surface of the rotor or the peripheral seal.
15. Once the entire belt is free of the rotor, slip it out through the gap underneath the rotor shaft. Then discard the old belt.

### 8.2.2 Installing the New Belt

1. Work the new belt through the gap underneath the rotor shaft.
2. Next, work the belt between peripheral seal and the rotor face until the belt is resting on top of the rotor. Take care not to damage the surface of the rotor or the peripheral seal. Make sure there are no twists in the belt.
3. Replace the rotor shaft support bracket and securely tighten the mounting screws. Then remove the 2 x 4 and 4 x 4 pieces of wood so the weight of the rotor is back on the rotor shaft support bracket.
4. If necessary, use your fingers and/or a non-metallic rounded object to unfold the

peripheral seals, restoring them to their original position around the rotor so they provide a double barrier against mixing air streams (see Figure 13).

5. Reinstall the horizontal and vertical face seals reversing the procedure you followed to remove them. Ensure the screw for the face seal joint is installed. Secure the mounting screws by hand; do not completely tighten them at this time.
6. The face seal brackets have slotted mounting holes. Using hand pressure, push the face seals toward the rotor to seat them lightly against the rotor surface. Use a standard business card, check the clearance by sliding it back and forth between the face seals and the rotor. There should only be a slight drag. If not, use a rubber mallet and a blade screwdriver to move the seal closer to the rotor. Place the tip of the screwdriver at the apex of the face seal bracket and GENTLY tap the end of the screwdriver with the rubber mallet. If the seal is too tight against the rotor surface, excessive friction and wear will occur to the rotor and the seal.
7. After the face seals are properly seated, tighten the screws on both the horizontal and vertical face seals to secure them
8. Reseal the union between the face seals and the peripheral seal with RTV silicone. Also, reseal the seam where the horizontal and vertical face seals meet. **DO NOT GET RTV ON THE ROTOR.** (Slip a piece of wax paper between the rotor and the area to be sealed (shown in Figure 11) to prevent RTV from sticking to the rotor surface.)
9. After applying the RTV silicone, allow it to set up to 6-8 hours then remove the wax paper used in step #8.
10. Replace the reactivation duct cover using the original fasteners and reseal the edges with RTV.
11. Replace the shaft retainer brackets (both sides of rotor).
12. Reinstall the rotor drive motor assembly to the floor of the cabinet and reconnect the wires.
13. Place the new drive belt on the motor drive pulley making sure the belt is lined up on the rotor drive cleats and the pulley.

14. Make sure all tools, silicone and equipment are removed from the unit, then replace the rotor access panel and close the cabinet doors.
15. When the unit is turned back on and in its normal operating mode, observe the rotor through the viewing window to ensure it turns freely and uninterrupted.

## 8.3 Replacing Seals

### 8.3.1 Removing Old Face Seals

1. Follow steps #1 to 9 in Section 8.2.1, "Removing the Old Belt". (Skip steps #5 and #6).
2. Visually inspect the seals for cracks or worn areas. (Inlet side and outlet side of rotor).
3. If seals are worn or cracked, they should be replaced.

---

**NOTE:** If the face seals are replaced on one side of the rotor, the seals on the opposite side should be replaced at the same time even if they do not appear worn or cracked.

---

### 8.3.2 Installing New Face Seals

1. Carefully slide the new rotor seals between the rotor surface and the support braces taking care not to scratch the rotor surface.
2. Follow steps #5 to 11 in Section 8.2.2 "Installing the New Belt".

### 8.3.3 Replacing Peripheral Seals

1. Follow steps #1 to 9 in Section 8.2.1 "Removing the Old Belt". Perform the steps on both sides of rotor, first removing the face seals from each side. (Skip steps #5 and #6).
2. Locate the point where the ends of the peripheral seal meet. Using a razor knife, break the RTV silicone bond.
3. Working from one end of the peripheral seal, carefully slide it out of the gap between the rotor and the mounting edge, removing it from the unit.
4. Repeat step #2 & 3 to the peripheral seal on the opposite side of the rotor.

5. Install the new peripheral seals in the same manner in which the old ones were removed (both sides of rotor).

**NOTE:** The flaps of the seal spreads outwards towards the center of the rotor and towards the outer edge against the angled support flange (see Figure 13). Ensure the flaps are not folded over.

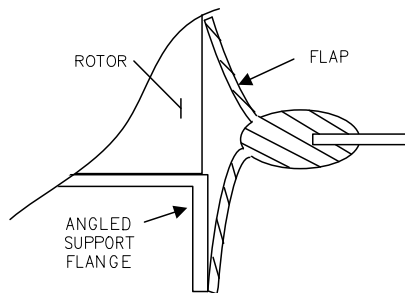

**Figure 13 - Peripheral Seal, Edge View**

6. Reattach the ends of the seals together with RTV silicone. DO NOT GET RTV ON THE ROTOR. (Slip a piece of wax paper between the rotor and the area to be sealed.)

## 8.4 Rotor Cleaning Instructions

Over time, dirt may accumulate on the surface of the rotor, blocking the openings of the flutes. The rotor may require periodic cleaning to maintain peak performance. Accumulated dirt can be removed from the surface of the rotor using a vacuum cleaner. Heavier dirt accumulations may be removed by washing the rotor with clean water. If the desiccant wheel is continuously exposed to air containing oil-laden vapors, it may be necessary to wash the rotor with a solution of water mixed with a light, non-alkaline detergent.

The following procedure describes the steps required to wash the rotor. At least two (2) people are required to efficiently and safely clean the rotor. Required materials include:

- Plastic sheeting to protect internal electrical components
- Dry vacuum
- Wet vacuum
- Wood block
- Hand-held spraying device (found at most hardware stores)
- Water/solution supply

### 8.4.1 Preparation

Operate the unit with the reactivation blower ON, the reactivation heater OFF, and the process blower OFF for two hours or until the entering and reactivation discharge air temperature is the same. Pre-cooling of the air stream is not necessary.

### 8.4.2 Unit Shut Down

1. Disconnect the power (turning the mode selector switch to the "Off" position DOES NOT disconnect the power).
2. Remove the rotor service panels to allow access to the unit and the desiccant rotor.
3. Loosen the drive belt tensioner and allow the belt to drop free from the drive system.
4. Carefully cover the drive motor with plastic to prevent the water/solution from coming in contact with the drive motor.

### 8.4.3 Cleaning

1. Note the initial starting point. Using an industrial dry vacuum cleaner with a clean, soft bristle brush applicator, draw air through the rotor flutes into the vacuum. Vacuum the entire surface of the rotor. With one person operating the vacuum, the other person slowly rotates the rotor by pulling on the drive belt.
2. Dry vacuum for at least one full revolution of the rotor. Repeat this process for the other side of the rotor (if possible).
3. After dry vacuuming, stabilize the rotor by placing a wood block under the rotor near the drive motor to prevent rotation during washing.

**NOTE:** DO NOT blow air through the flutes as any particulate blown free would scatter through the work site.

4. Open the drain holes in the floor of the cabinet to allow the cleaning solution to flow out.

**NOTE:** Ensure that a means of collecting the cleaning solution for proper disposal is provided.

5. With the water/solution in the spraying device, flush the rotor through the lower half section (see Figure 14).

**NOTE:** If using a detergent solution, thoroughly rinse the rotor with clean water after flushing with the solution.

6. Remove the wood block and rotate the wet part of the rotor 1/4 turn AWAY from the reactivation section of the cassette. Replace the wood block under the rotor.
7. Continue washing/rinsing the next section of the rotor. At the same time, wet vac the rotor at the upper section of the cassette. Then dry vac the same portion of the rotor. After dry vacuuming, remove the wood block and rotate the rotor in the same direction 1/4 turn. Begin washing/rinsing and vacuuming as before.
8. Continue this operation until the entire rotor has been washed, rinsed, and vacuumed.
9. When finished, use the wet/dry vac to remove any water from around the hub, spokes, and

flange areas. Spin/rotate the rotor to check for balance. An unbalanced rotor may indicate the need for more wet/dry vacuuming. Repeat the drying operations as necessary.

10. Drain, wet vac, and dry mop the bottom of the cabinet on both the upstream and downstream side of the rotor/cassette.
11. Remove the wood block, the plastic sheeting, and make sure the rotor turns freely and there is no moisture around the base of the drive motor.

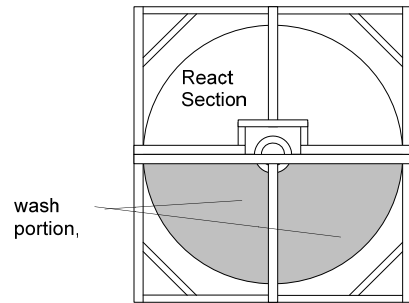

Wash the bottom half of the rotor

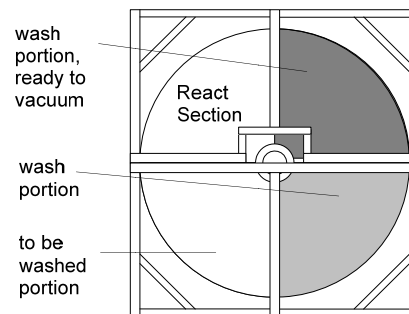

Rotate 1/4 turn away from the reactivation section to vacuum/dry.

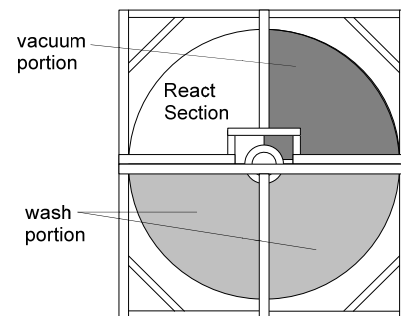

Wash the next section of the rotor, then rotate as before to vacuum/dry.

**Figure 14 - Rotor Washing**

12. Align and reinstall the rotor drive belt and tensioner. Replace all service panels (making sure all tools/supplies are removed from unit first). Reconnect power.
13. Operate the unit with the reactivation blower ON, the reactivation heater OFF and the process blower OFF for 60 minutes, then resume normal unit operation.
14. After 6 hours, check the performance of the unit. If the process air discharge is excessively humid (greater than 10% of original performance), turn the process blower OFF and run the reactivation heater and blower for another 2 hours to "reactivate" the desiccant. If conditions still do not return to normal, consult the factory.

## 8.5 Rotor Repair

Minor repairs, such as rotor cracks, can be performed by service technicians when required. See Figure 16. Materials needed include:

- Masking tape
- Small piece of stiff cardboard with flat edge
- 100% Silicone tube
- Caulking gun

**NOTE:** These instructions are for small cracks in the rotor surface. For large cracks or for information on replacing the rotor, contact SATS Product Support at (888) 529-1266.

1. Turn the unit OFF and disconnect main power. Open the cabinet doors and remove the desiccant rotor access panels.
2. Remove the belt from the rotor drive pulley so you can turn the rotor freely. Position the rotor so you have unobstructed access to the cracked portion of the rotor.
3. Apply masking tape to the face of the rotor on the right and left sides of the crack. Allow for about two "corrugations" on each side of the crack.
4. Apply 100% silicone to the crack, keeping the angled cut of the silicone tube parallel and very close to the surface of the rotor to ensure good penetration. Allow the silicon seal to extend ½" beyond the crack. For best results, apply the silicone in an upward motion to push the silicone into the crack.

5. After applying the silicone, take the piece of cardboard, and at a 45 degree angle, drag the cardboard over the bead to press the silicone into the crack and make the surface of the silicone smooth and flush with the face of the rotor. This will further enhance the penetration of the silicone and will ensure that the silicone does not protrude above the surface of the rotor.
6. Immediately after pressing the silicone into the crack with the cardboard, remove the masking tape. This must be done before the silicone starts to cure, or "skin over".
7. Allow the silicone 24 hours to fully cure prior to running the unit. Should any questions or problems arise, contact SATS Product Support at (888) 529-1266.

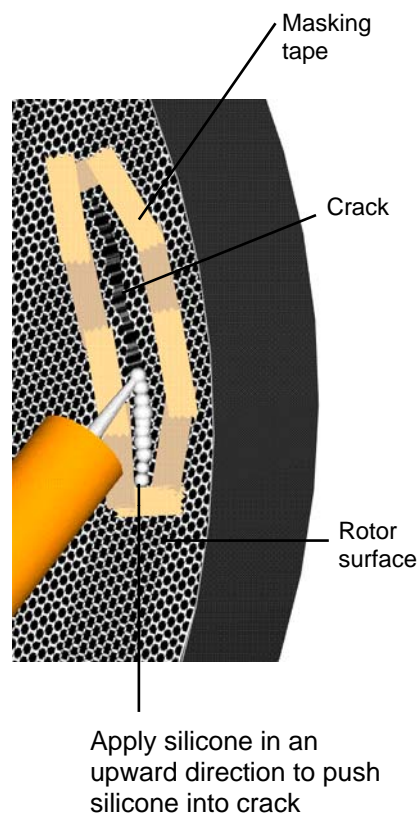

Figure 15 - Rotor Scratch Repair

## 9.0 SATS PRODUCT SUPPORT

SATS provides its customers with Product Support which not only provides technical support and parts but the following additional services, as requested:

- Performance Evaluations
- Start-up Assistance
- Training

### 9.1 Technical Support

The SATS Technical Support Department is dedicated to the prompt reply and solution to any problem encountered with a unit. Should a problem develop that cannot be resolved using this manual, you may contact (888) 529-1266 Monday through Friday from 8:00 a.m. to 8:00 p.m. EST. If a problem occurs after business hours, provide your name and telephone number. One of our service technicians will return your call.

When calling to obtain support, it is important to have the following information readily available, (information is found on unit's nameplate):

- Unit Model Number (SD2-XXX-XX-X)
- SATS Sales Order Number (123456)
- SATS Item Number (123456)
- Unit Serial Number (1234567)
- Description of Problem

### 9.2 Obtaining Warranty Parts

Warranty inquiries are to be made through the Technical Support Department at (888) 529-1266 Monday through Friday from 8:00 a.m. to 8:00 p.m. EST. A service technician at SATS will troubleshoot the system over the telephone with a field service technician to determine the defect of the part. If it is determined that the part may be defective a replacement part will be sent UPS ground. If the customer requests that warranty part(s) be sent by any other method than UPS ground the customer is responsible for the shipping charges. If you do not have established credit with SATS you must provide a freight carrier account number.

A written (or faxed) purchase order is required on warranty parts and must be received prior to 12:00 p.m. for same day shipment. The purchase order must contain the following items:

- Purchase Order Number
- Date of Order

- SATS Stated Part Price
- Customer Billing Address
- Shipping Address
- Customer's Telephone and Fax Numbers
- Contact Name
- Unit Model No., Serial No. & SATS Item No.

The customer is responsible for the shipping cost incurred for returning the defective part(s) back to SATS. Return of defective part(s) must be within 30 days at which time an evaluation of the part(s) is conducted and if the part is found to have a manufacturing defect a credit will be issued.

When returning defective part(s), complete the Return Material Authorization Tag and the address label provided with the replacement part.

See the SATS Standard Warranty located in section one of this manual.

### 9.3 Obtaining Spare/Replacement Parts

Selected spare parts are recommended to have on hand to help ensure minimal down time for the system. Spare and replacement parts requests are to be made through Product Support by fax (301) 620-1396, telephone (240) 529-1399 or E-mail (parts@stulz-ats.com). Quotes are given for specified listed parts for a specific unit.

SATS accepts Visa and MasterCard. SATS may extend credit to its customers; a credit application must be prepared and approved (this process could take one week).

A 25% minimum restocking charge will be applied on returned stocked parts that were sold as spare/replacement parts. If the returned part is not a stocked item, a 50% restocking charge may be applied. Additionally a Return Material Authorization Number is required when returning parts. To receive credit for returned repair/replacement parts, the parts must be returned to SATS within 30 days of the purchase date. Spare part sales over 30 days old will be considered final and the parts will remain the sole property of the ordering party.

# **Appendix A**

## **Forms**





**DESICAIR PRODUCT DIVISION**

Telephone: (301) 620-2033  
Facsimile: (301) 620-1396

**Appendix A- Forms**

**Checklist for Completed Installation**

- 1 Proper clearances for service access have been maintained around equipment.
- 2 Equipment is level and mounting fasteners (if applicable) are tight.
- 3 Foreign materials removed from inside and around equipment (shipping materials, blower lockdown bolts construction materials, tools, etc.).
- 4 Blowers rotate freely without unusual noise.
- 5 Filter(s) installed (if required).
- 6 Ductwork installed and sealed against leaks.
- 7 Air dampers installed in ductwork (if required).
- 8 Incoming line voltage matches equipment nominal nameplate rating  $\pm$  tolerance.
- 9 Main power wiring connections to the equipment, including earth ground, have been properly installed according to applicable codes.
- 10 Customer supplied main power branch circuit protection devices/fuses have proper ratings for the equipment.
- 11 All control wiring completed according to applicable codes to wall mounted control panel, temperature/RH sensor transmitter, etc. (as applicable).
- 12 Control Sensors polarity (+/-) wired correctly.
- 13 All control wiring completed to terminal positions for customer control and monitoring lines.
- 14 All wiring connections are tight.
- 15 Piping, control valves, etc. installed (if required).
- 16 All field installed piping leak tested.
- 17 Gas inlet supply pressure matches nominal nameplate rating (if required).

Name \_\_\_\_\_ Date \_\_\_\_\_

Company \_\_\_\_\_





**DESICAIR PRODUCT DIVISION**

Telephone: (301) 620-2033  
Facsimile: (301) 620-1396

**Periodic General Maintenance Checks and Services Checklist**

Date: \_\_\_\_\_ Prepared By: \_\_\_\_\_  
Model Number: \_\_\_\_\_ Serial Number: \_\_\_\_\_  
Item Number: \_\_\_\_\_

**Monthly**

| <u>Filters</u>                                                                                                              | <u>Rotor</u>                                           | <u>Reactivation Heater</u>                            |
|-----------------------------------------------------------------------------------------------------------------------------|--------------------------------------------------------|-------------------------------------------------------|
| <input type="checkbox"/> Cleanliness                                                                                        | <input type="checkbox"/> Check Condition of Rotor Face | <input type="checkbox"/> Inspect Flame (Gas Units)    |
| <input type="checkbox"/> No Obstructions                                                                                    | <input type="checkbox"/> Check Condition of Seals      | <input type="checkbox"/> Clean Coils (Electric Units) |
| <b><u>Miscellaneous</u></b>                                                                                                 |                                                        |                                                       |
| <input type="checkbox"/> Check and Tighten Loose Fasteners and Couplings                                                    |                                                        |                                                       |
| <input type="checkbox"/> Check Condition of Belts                                                                           |                                                        |                                                       |
| <input type="checkbox"/> Check Differential Pressure Drop Readings on Gauges                                                |                                                        |                                                       |
| <input type="checkbox"/> Check Gas Lines for Leaks (If Applicable)                                                          |                                                        |                                                       |
| <input type="checkbox"/> Status Indicator Lights "Press to Test" Feature Operates Properly (Should Illuminate When Pressed) |                                                        |                                                       |

**Quarter-Annually**

|                                                                   |                                                                           |
|-------------------------------------------------------------------|---------------------------------------------------------------------------|
| <input type="checkbox"/> Tighten Electrical Connections           | <input type="checkbox"/> Check Motors, Lubricate Per Maintenance Schedule |
| <input type="checkbox"/> Check Contacts on Contactors for Pitting | <input type="checkbox"/> Check Gas Pressure Per Unit Name Plate           |
| <input type="checkbox"/> Clean Unit as Necessary                  | <input type="checkbox"/> Clean Coils as Necessary                         |
| <input type="checkbox"/> Check Motor Amps Per Unit Name Plate     |                                                                           |

**Annually**

|                                                                                                          |
|----------------------------------------------------------------------------------------------------------|
| <input type="checkbox"/> Conduct a Complete Check of All Services Listed Above and Clean Unit's Interior |
| <input type="checkbox"/> Inspect Wiring For Fraying, Discoloration                                       |
| <input type="checkbox"/> Inspect Piping System for Leaks and Corrosion (If Applicable)                   |

**Notes:** \_\_\_\_\_  
\_\_\_\_\_  
\_\_\_\_\_

**Signature:** \_\_\_\_\_

\*\*\* If factory assistance is required for any reason, provide the model number, serial number and SATS item number found on the unit nameplate. This will speed the process and insure accuracy of information. \*\*\*



# **Appendix B**

## **Unit Performance Curves**

Note: Unit Performance Curves are provided for reference only. Data is based on reactivation entering air conditions at 95°F/130 GPP. Refer to the Technical Data Sheet provided with the unit for specific unit performance data.



## Performance for 400FPM Rotor Face Velocity

### Grains Per Pound (GPP)

1. Enter the Performance Chart from the X-axis at the entering process air moisture in grains per pound (GPP).
2. Move vertically in a straight line to intersect the curve closest to the entering air temperature. Interpolate as required.
3. Move horizontally to the left and intersect the Y-axis. This point represents the leaving process air moisture from the dehumidifier in GPP.

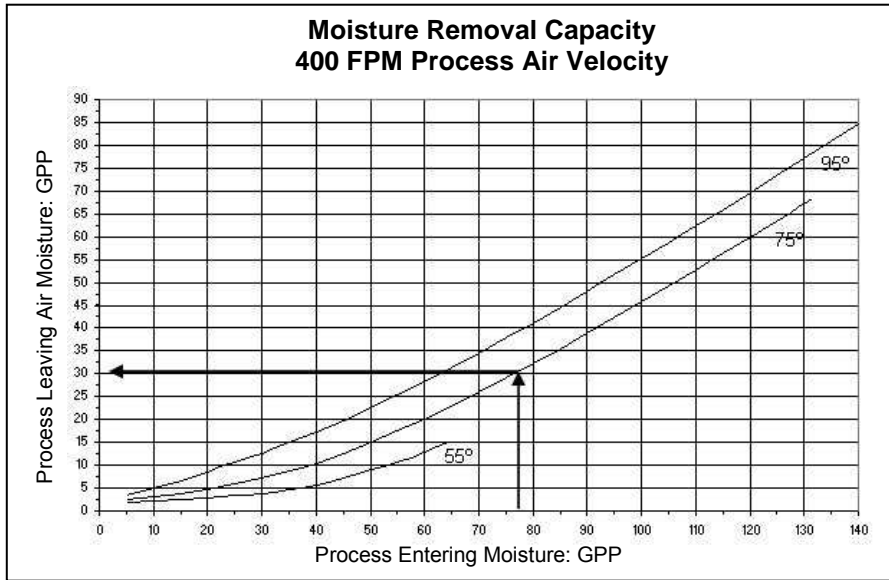

### Leaving Temperature

1. Enter the Performance Chart from the X-axis at the entering process air moisture in grains per pound (GPP).
2. Move vertically in a straight line to intersect the curve closest to the entering air temperature. Interpolate as required.
3. Move horizontally to the left and intersect the Y-axis. This point represents the leaving process air moisture from the dehumidifier in °F.

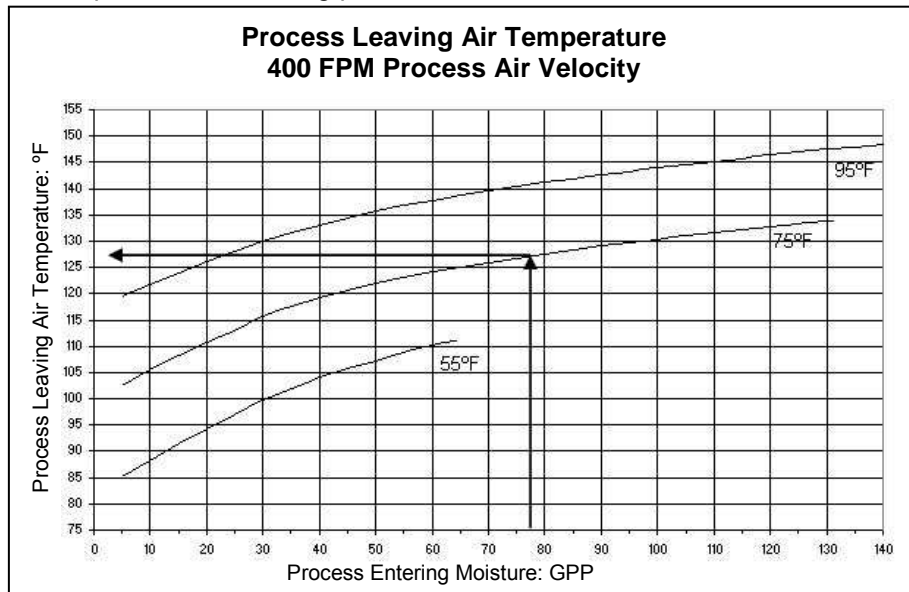

**NOTE:** Process air outlet temperatures as shown are maximum values at standard full rated heater output. The actual process outlet temperature will be lower when the heater output is below full rated output. This condition will occur during heater modulation cycles due to partial loading of the dehumidifier.

**Performance for 600 FPM Rotor Face Velocity  
Grains Per Pound (GPP)**

1. Enter the Performance Chart from the X-axis at the entering process air moisture in grains per pound (GPP).
2. Move vertically in a straight line to intersect the curve closest to the entering air temperature. Interpolate as required.
3. Move horizontally to the left and intersect the Y-axis. This point represents the leaving process air moisture from the dehumidifier in GPP.

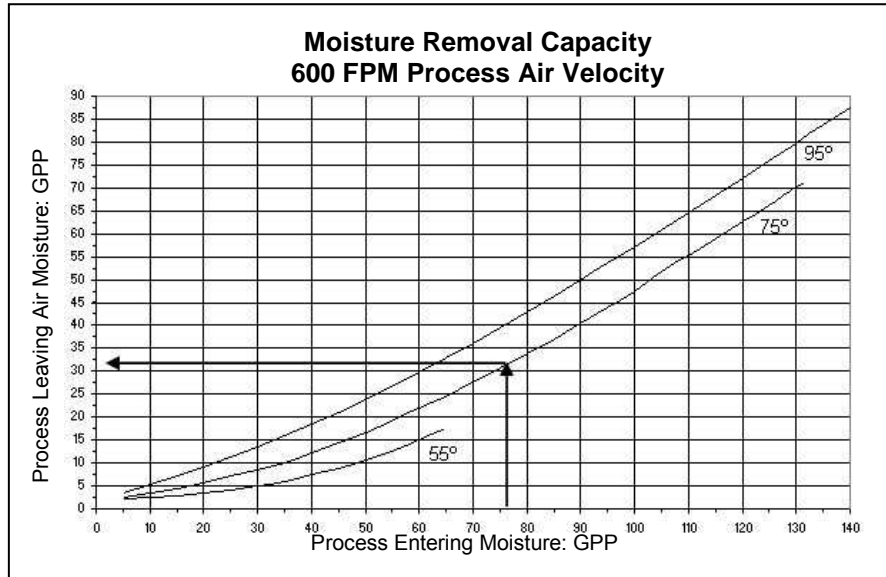

**NOTE:** Process air outlet temperatures as shown are maximum values at standard full rated heater output. The actual process outlet temperature will be lower when the heater output is below full rated output. This condition will occur during heater modulation cycles due to partial loading of the dehumidifier.

**Leaving Temperature**

1. Enter the Performance Chart from the X-axis at the entering process air moisture in grains per pound (GPP).
2. Move vertically in a straight line to intersect the curve closest to the entering air temperature. Interpolate as required.
3. Move horizontally to the left and intersect the Y-axis. This point represents the leaving process air moisture from the dehumidifier in °F.

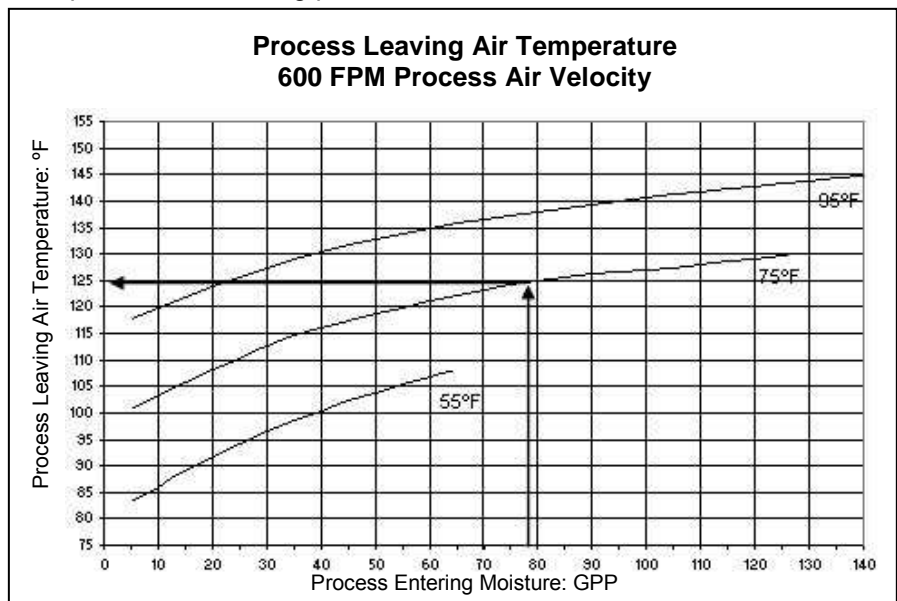

**Performance for 800 FPM Rotor Face Velocity**

**Grains Per Pound (GPP)**

1. Enter the Performance Chart from the X-axis at the entering process air moisture in grains per pound (GPP).
2. Move vertically in a straight line to intersect the curve closest to the entering air temperature. Interpolate as required.
3. Move horizontally to the left and intersect the Y-axis. This point represents the leaving process air moisture from the dehumidifier in GPP.

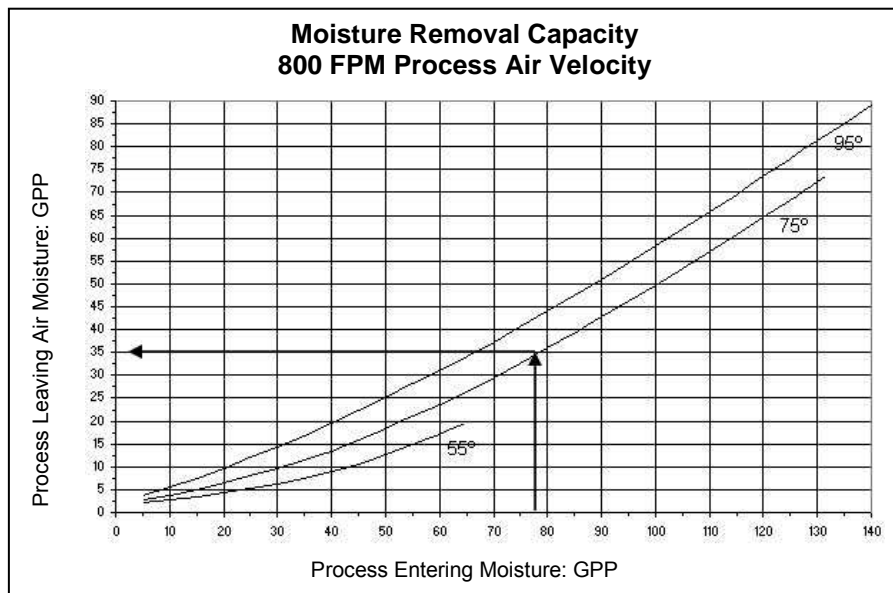

**Leaving Temperature**

1. Enter the Performance Chart from the X-axis at the entering process air moisture in grains per pound (GPP).
2. Move vertically in a straight line to intersect the curve closest to the entering air temperature. Interpolate as required.
3. Move horizontally to the left and intersect the Y-axis. This point represents the leaving process air moisture from the dehumidifier in °F.

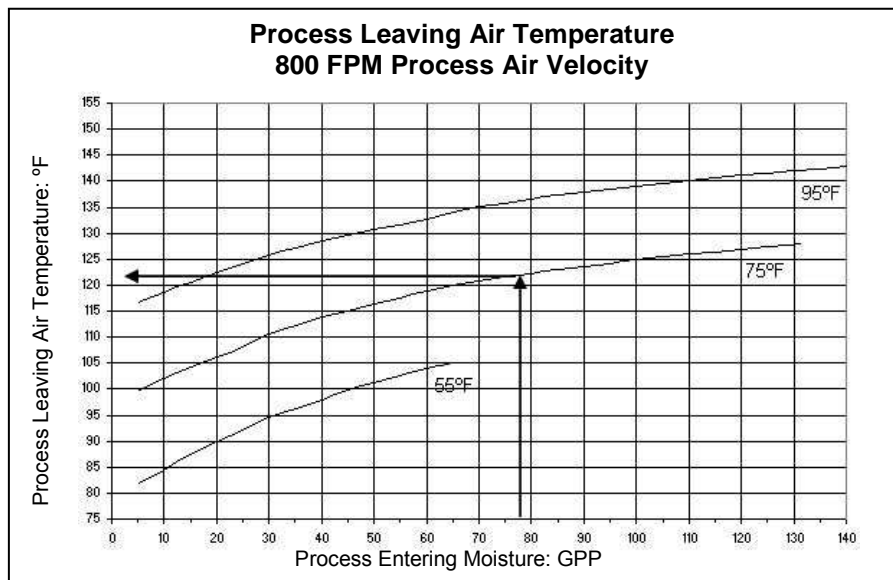

**NOTE:** Process air outlet temperatures as shown are maximum values at standard full rated heater output. The actual process outlet temperature will be lower when the heater output is below full rated output. This condition will occur during heater modulation cycles due to partial loading of the dehumidifier.



**APPENDIX C-GLOSSARY**

**Terms and Abbreviations**

|                  |                                                                                  |                 |                                                                                        |
|------------------|----------------------------------------------------------------------------------|-----------------|----------------------------------------------------------------------------------------|
| <b>Absorb</b>    | Penetration of Vapor Molecules Into the Molecular Structure of Another Substance | <b>In. w.g.</b> | Inches of Water Gauge                                                                  |
| <b>Adsorb</b>    | Attraction of Vapor Molecules to the Surface of Another Substance                | <b>KVA</b>      | Kilo-VoltAmp (One Thousand Volt Amps)                                                  |
| <b>BTU/Hr</b>    | British Thermal Units Per Hour                                                   | <b>KW</b>       | Kilo-Watts (One Thousand Watts)                                                        |
| <b>CFM</b>       | Cubic Feet Per Minute                                                            | <b>LRA</b>      | Locked Rotor Amps                                                                      |
| <b>D-STAT™</b>   | Cycles Dehumidifier On & Off To Maintain Relative Humidity                       | <b>MFS</b>      | Maximum Fuse Size                                                                      |
| <b>Desorb</b>    | Removal of Absorbed or Adsorbed Vapor Molecules                                  | <b>MSDS</b>     | Material Safety Data Sheet                                                             |
| <b>Dew Point</b> | Temperature At Which Humid Air Becomes 100% Saturated                            | <b>MCA</b>      | Minimum Circuit Ampacity                                                               |
| <b>Dry Bulb</b>  | Temperature of Air As Measured By a Thermometer.                                 | <b>NEC</b>      | National Electric Code                                                                 |
| <b>°F</b>        | Degrees Fahrenheit                                                               | <b>PH</b>       | Phase                                                                                  |
| <b>FLA</b>       | Full Load Amperage                                                               | <b>PSI</b>      | Pounds per Square Inch                                                                 |
| <b>FOB</b>       | Freight On Board                                                                 | <b>PSIG</b>     | Pounds Per Square Inch Gauge                                                           |
| <b>GPP</b>       | Grains Per Pound                                                                 | <b>RH</b>       | Relative Humidity                                                                      |
| <b>HP</b>        | Horse Power                                                                      | <b>SATS</b>     | Stulz Air Technology Systems, Inc                                                      |
| <b>Hz</b>        | Hertz (Frequency)                                                                | <b>VAC</b>      | Voltage, Alternating Current                                                           |
| <b>In. w.c.</b>  | Inches of Water Column                                                           | <b>Wet Bulb</b> | Temperature of air as sensed by thermometer with a water saturated wick over the bulb. |

# Globally close to you

Stulz-ATS, located in Frederick, MD USA, is part of The STULZ Group with Headquarters in Hamburg, Germany and production facilities world wide. Our network of manufacturer's representatives and sales partners span the globe, providing innovative solutions to your unique environmental control needs.

[www.stulz-ats.com](http://www.stulz-ats.com)



Stulz Air Technology Systems, Inc.  
1572 Tilco Drive, Frederick, Maryland 21704  
Phone: (301) 620-2033, Fax: (301) 662-5487  
Email: [info@stulz-ats.com](mailto:info@stulz-ats.com)  
[www.stulz-ats.com](http://www.stulz-ats.com)



*ISO-9001:2001 Quality Registered*

OD20080-

SD2-5000-96 Installation, Operation & Maintenance - Specifications are subject to change without notice.